

**SERVICE INFORMATION**

**BOOTH EQUIPMENT**

Each 10' x 10' booth will be set up with 8' high blue back drape, 3' high blue side dividers, (1) 6' L x 30" H x 24" W blue draped table, (2) side chairs, and (1) wastebasket. Booths 300 sqft or less will receive a one-line identification sign. Booths larger than 300 sqft may receive a one-line identification sign upon request.

**EXHIBIT HALL CARPET**

The exhibit area is carpeted. Exhibitors will be permitted to install different color carpet at their expense. To enhance the appearance of your booth, rental carpet is available through Freeman. Please refer to the Carpet Brochure and Order Form located in this manual.

**DISCOUNT PRICE DEADLINE DATE**

**Order early to take advantage of advance order discount rates, place your order by August 21, 2017.**

**SHOW SCHEDULE**

**EXHIBITOR MOVE-IN**

For more information and helpful hints on pre-show procedures and move-in, please go to [Pre-Show FAQ](#).

Sunday            September 10, 2017        6:00 AM - 6:00 PM

**EXHIBIT HOURS**

Monday	September 11, 2017	7:00 AM - 8:30 AM	Breakfast with Exhibitors
Monday	September 11, 2017	10:30 AM - 11:00 AM	Refreshment Break with Exhibitors
Monday	September 11, 2017	12:00 PM - 2:00 PM	Lunch with Exhibitors
Monday	September 11, 2017	3:30 PM - 4:00 PM	Refreshment Break with Exhibitors
Monday	September 11, 2017	5:30 PM - 7:00 PM	Evening Reception with Exhibitors
Tuesday	September 12, 2017	7:00 AM - 8:30 AM	Breakfast with Exhibitors
Tuesday	September 12, 2017	10:00 AM - 11:00 AM	Refreshment Break with Exhibitors
Tuesday	September 12, 2017	12:00 PM - 2:00 PM	Lunch with Exhibitors
Tuesday	September 12, 2017	3:30 PM - 4:00 PM	Refreshment Break with Exhibitors

**EXHIBITOR MOVE-OUT**

For more information and helpful hints on post-show procedures and move-out, please go to [Post-Show FAQ](#).

Tuesday            September 12, 2017        4:00 PM - 6:00 PM

**We will begin returning empty containers at the close of the show.**

**DISMANTLE AND MOVE-OUT INFORMATION**

All exhibitor materials must be removed from the exhibit facility by Tuesday, September 12, 2017 at 6:00 PM.

To ensure all exhibitor materials are removed from the exhibit facility by the Exhibitor Move-Out deadline, please have all carriers check-in by Tuesday, September 12, 2017 at 5:00 PM.

**SERVICE CONTRACTOR CONTACTS / INFORMATION:**

**FREEMAN**

841 Joseph E Lowery Blvd NW  
 Atlanta, GA 30318  
 (404) 253-6494 fax (469) 621-5610  
 FreemanAtlantaES@freeman.com

**FREEMAN EXHIBIT TRANSPORTATION**

(800) 995-3579 US & Canada or +1(512) 982-4187 Outside the US or +1(817) 607-5183  
 International Shipping Services or fax (469) 621-5810 or email exhibit.transportation@freeman.com

**FREEMAN ONLINE®**

**Take advantage of discount pricing by ordering online at [www.freeman.com](http://www.freeman.com) by August 21, 2017.**

Using the enhanced FreemanOnline, you will enjoy easy access to added features and functions as well as the high caliber of Freeman services you've come to expect — **before, during** and **after** your show. Additionally, you can now access FreemanOnline from any device — **desktop, laptop, tablet** or via our new **FreemanOnline Mobile App**.

To place online orders, you will be required to enter your unique Username and Password. If this is your first time to use FreemanOnline, click on the "Create an Account" link. To access FreemanOnline without using the email link, visit [www.freeman.com](http://www.freeman.com). You can also download and use the FOL Mobile App from the Apple or Android store, or here: [folmobile.freeman.com](http://folmobile.freeman.com). A mobile web version of the FreemanOnline Mobile App is available to extend mobile use for those users that do not have an Apple or Android device or who do not want to download the app.

If you need assistance with FreemanOnline, please call our Customer Support Center at (888) 508-5054 Toll Free US and Canada or +1(512) 982-4186 Local and International.

**SHIPPING INFORMATION**

**Warehouse Shipping Address:**

**Exhibiting Company Name / Booth #**  
**IBTTA 85th ANNUAL MEETING**  
**C/O Freeman**  
**841 Joseph E Lowery Blvd NW**  
**Atlanta, GA 30318**

**OFFICE & WAREHOUSE CLOSED**

**Monday, September 04, 2017 for Holiday**

Freeman will accept crated, boxed or skidded material beginning Friday, August 11, 2017 at the above address. Material arriving after September 01, 2017 will be received at the warehouse with an additional after deadline charge. Warehouse materials are accepted at the warehouse Monday through Friday between the hours of 8:00 AM - 4:00 PM. If required, provide your carrier with this phone number: (404) 253-6494.

***Please Note: Due to limited storage space and material handling services at the Hotel, all exhibitor freight should be sent to the Freeman Warehouse. If special circumstances require you to ship directly to the Hotel, please call Freeman Exhibitor Services to provide you with the ship to address, instructions, and specific receiving dates.***

Freeman will receive shipments at the exhibit facility beginning Sunday, September 10, 2017 at 10:00 AM. Shipments arriving before this date may be refused by the facility. Any charges incurred for early freight accepted by the facility will be the responsibility of the exhibitor. If required, provide your carrier with this phone number: (404) 253-6494.

**Please note: All items and materials that must be brought into the facility are subject to Material Handling Charges and are the responsibility of the Exhibitor. This also applies to items not ordered through the Official Show Vendors. Refer to the Material Handling form for charges for the service.**

Please be aware that disposal of exhibit properties is not included as part of your material handling charges. Please contact Freeman for your quoted rates and rules applicable to disposal of your exhibit properties.

**LABOR INFORMATION**

Union Labor may be required for your exhibit installation and dismantle. Please carefully read the UNION RULES AND REGULATIONS to determine your needs. Exhibitors supervising Freeman labor will need to pick up and release their labor at the Labor Desk. Refer to the order form under Display Labor for Straight time and Overtime hours.

**ASSISTANCE**

We want you to have a successful show. If we can be of assistance, please call our Exhibitor Services Department at (404) 253-6494.

**WE APPRECIATE YOUR BUSINESS!**

## FREEMAN GENERAL INFORMATION

### TRANSLATION SERVICES

Freeman is pleased to offer a new service for our international exhibitors that provides quick interpretation and translation in 150 languages. This service will not only interpret for us on a three way conversation, but also translate emails from customers. To access this feature you may contact Freeman Exhibitor Services at (404) 253-6494 or Freeman's Customer Support Center at (888) 508-5054.

### HELPFUL HINTS

#### SAVE MONEY

Order early to take advantage of advance order discount rates, place your order by August 21, 2017.

#### AVOID DELAY

Ship early to avoid delays. Shipments arriving late at show site will cost you money, time and business!

#### SAFETY TIPS

Use a ladder, not a chair. Standing on chairs, tables and other rental furniture is unsafe and can cause injury to you or to others. These objects are not designed to support your standing weight.

Be aware of your surroundings. You are in an active work area with changing conditions during move-in and move-out. Pay attention. Look for obstacles, machinery and equipment that are in use.

Keep your eyes open for scooters and forklifts. The drivers of these vehicles may not be able to see you.

Stay clear of dock areas, trucks and trailers. These areas can be particularly dangerous.

Prevent electrical shocks, falling items and damage to materials. Do not attach items or equipment to the drapes or metal framework provided for your booth. This can cause serious injury or damage to materials.

We discourage children from being in the exhibit hall during installation and dismantle. If children are present during installation and dismantle, they must be supervised by an adult at all times.

Freeman does not ship or handle Hazardous Materials. If any materials you are shipping to the event fall into this category, please contact Freeman to be sure the material will be allowed at the facility and by the association. In addition, if authorized by the facility and the association, you will need to make separate arrangements for the transport and handling of the approved materials, since Freeman will not transport or handle them.

The operation or use of all motorized lifts and motorized material handling equipment for installation/dismantle of exhibits is NOT permitted by exhibitors or by their exhibitor appointed contractors (EAC's). Thank you for your cooperation.

#### EXHIBITOR ASSISTANCE

For more information and helpful hints on pre-show procedures and move-in, please go to [Pre-Show FAQ](#).

For more information and helpful hints on post-show procedures and move-out, please go to [Post-Show FAQ](#).

Call Freeman's Exhibitor Services department at (404) 253-6494 with any questions or needs you may have.



# REDUCING YOUR FOOTPRINT

Freeman actively engages in green practices within day-to-day operations and is committed to producing events in the most environmentally friendly way possible. Freeman has collaborated with a number of customers to make their events greener and is dedicated to broadening this effort.

## Green Tips for Exhibitors

Interested in going Green and saving money with your exhibit booth? Follow these tips to assist you in making your sustainable booth strategies at least cost-neutral, and possibly cost-saving!

### Supplies and Ordering

- Order exhibit supplies early and utilize online ordering systems to eliminate paper waste.
- Consider renting a booth from Freeman or buying materials locally, preventing shipping cost and lowering emissions.
- Rent Freeman Classic Carpet which contains recycled content and is also recyclable.
- Provide giveaways made of recycled, responsibly grown natural fiber, nontoxic and biodegradable materials. Ensure giveaways are useful, not merely promotional in nature. Electronic Giveaways are smart and trendy, like a USB storage drive with your content already loaded.

### Printing, Recycling and Waste Management

- Encourage less printing and provide more information digitally when it comes to booth literature, fulfilling requests via email and website referrals.
- If you need to print, use a local printer in the city where the show will be held and choose paper that contains at least 50% post-consumer recycled content.
- Ask Freeman about new paper-based signage materials that are comparably priced to plastic. There are good alternatives to foam core and PVC which are not as easily recyclable.
- Participate in the exhibit donation program by providing materials that are eligible for donation to local charities, such as pens, bags and notepads.

### Shipping and Transportation

- If you must ship materials, planning out your booth in a timely way to meet shipping deadlines can also help maximize consolidation and cost-savings.
- Choose a SmartWay™-certified hauler at no additional cost to ensure your transportation company is practicing sustainable shipping.
- Set a goal to leave no trace behind by shipping out all booth properties and packing materials and donating extra giveaways thereby minimizing any waste for the show.
- If you are attending another trade show that many of your fellow exhibitors are also participating in, ask your General Service Contractor or Show Management to set up a caravan service to save on fuel emissions—and cost of transportation.

### Personnel and Best Practices

- Take advantage of local or regional representatives to staff your booth, rather than bringing staff from far away offices, reducing travel cost.
- Bring Green as part of your company message providing recycling bins in your booth and information on what you have done to exhibit in a sustainable way.

These steps can help as we all strive to make smarter and more environmentally sound decisions. For more information on the Freeman Sustainability Initiative, contact [goinggreen@freemanco.com](mailto:goinggreen@freemanco.com).



# FREEMAN

841 Joseph E Lowery Blvd N W  
Atlanta, GA 30318  
(404) 253-6494 Fax: (469) 621-5610

DISCOUNT PRICE  
DEADLINE DATE  
AUGUST 21, 2017

INCLUDE THIS FORM  
WITH YOUR ORDER  
PLEASE USE BLACK INK

NAME OF SHOW: **IBTTA 85th ANNUAL MEETING / SEPTEMBER 10 - 13, 2017**

---

COMPANY NAME: \_\_\_\_\_ BOOTH #: \_\_\_\_\_

---

ADDRESS: \_\_\_\_\_ BOOTH SIZE : \_\_\_\_\_ X

---

CITY/STATE/ZIP: \_\_\_\_\_

---

PHONE: \_\_\_\_\_ EXT.: \_\_\_\_\_ FAX #: \_\_\_\_\_

---

SIGNATURE: \_\_\_\_\_ PRINT NAME: \_\_\_\_\_

---

CONTACT'S E-MAIL: \_\_\_\_\_

E-MAIL FOR INVOICE: \_\_\_\_\_  **Check if you are a new Freeman customer**  
**Invoices will be sent by e-mail; please provide e-mail address of the person who reconciles your invoices if different than contact's email.**

## METHOD OF PAYMENT

BY SUBMITTING THIS FORM VIA FAX OR POSTAL MAIL OR ORDERING MATERIALS OR SERVICES FROM FREEMAN, YOU AGREE TO BE BOUND BY ALL TERMS & CONDITIONS INCLUDED IN YOUR SERVICE MANUAL.

**COMPANY CHECK**  
 Please make check payable to: Freeman  
 Checks must be in U.S. funds drawn on a U.S. or Canadian bank. ("U.S. FUNDS" MUST BE PRE-PRINTED on Canadian checks.)  
**Please reference (435539) on your remittance.**

**BANK TRANSFER**  
 Bank transfer to Bank of America, N.A.; Dallas, TX  
*Wire Transfer*  
 ABA#: 026009593 ACCT# 1252039192 Freeman  
*International Wire Transfer*  
 Swift Code: BOFAUS3N ACCT# 1252039192 Freeman  
*ACH Direct Deposit*  
 ABA#:111000012 ACCT# 1252039192 Freeman  
**Please reference Name of Show & Booth Number so we can properly credit your account.**  
**Note: Customers are responsible for any bank processing fees.**

**CREDIT/DEBIT CARD**  
 For your convenience, we will use this authorization to charge your credit/debit card account for your advance orders, and any additional amounts incurred as a result of show site orders placed by your representative. These charges may include all Freeman companies, or any charges which Freeman may be obligated to pay on behalf of Exhibitor, including without limitation, any shipping charges. Please complete the information requested below:

**AMERICAN EXPRESS**     **MASTER CARD**     **VISA**    **We do not accept credit card information via email.**

ACCOUNT NO.: \_\_\_\_\_ EXP. DATE: \_\_\_\_\_

CARDHOLDER NAME (PRINT): \_\_\_\_\_ SIGNATURE: \_\_\_\_\_

CARDHOLDER BILLING ADDRESS: \_\_\_\_\_

CITY/STATE/ZIP: \_\_\_\_\_

## ENTER TOTALS HERE

FURNISHINGS & ACCESSORIES	CARPET	CLEANING/ SHAMPOOING	PORTER SERVICE	RENTAL EXHIBITS & ACCESSORIES	SIGNS	INSTALLATION LABOR	DISMANTLE LABOR
MATERIAL HANDLING	RIGGING INSTALLATION	RIGGING DISMANTLE	EXHIBIT TRANSPORTATION	HANGING SIGNS	GRAND TOTAL		

- Remember to order in advance to save time and money. You may place your order by phone, fax, mail, or use our online ordering service at: [www.freeman.com](http://www.freeman.com).
- Orders received after the deadline or without payment will be charged the Standard price.
- Copies of invoices may be picked up from the Service Desk prior to show closing.
- If you have questions or need assistance with any items not listed, please call and ask for Exhibitor Sales.

**FREEMAN method of payment**

# FREEMAN

841 Joseph E Lowery Blvd N W  
Atlanta, GA 30318  
(404) 253-6494 Fax: (469) 621-5610

## IBTTA 85th ANNUAL MEETING / SEPTEMBER 10 - 13, 2017

**In order to authorize Freeman to invoice a third party for payment of services rendered to exhibitors, both the exhibiting company and the third party must complete this form and return it at least 14 days prior to show move-in.**

### EXHIBITING COMPANY AUTHORIZATION OF THIRD PARTY BILLING

"We understand and agree that we, the exhibiting company, are ultimately responsible for payment of charges and agree by submitting this form or ordering materials or services from Freeman, to be bound by all terms and conditions as described in the Terms & Conditions section of this service manual. In the event that the named third party does not discharge payment of the invoice prior to the last day of the show, charges will revert back to the exhibiting company. All invoices are due and payable upon receipt, by either party. The items checked below are to be invoiced to the third party."

BY SUBMITTING THIS FORM VIA FAX OR POSTAL MAIL OR ORDERING MATERIALS OR SERVICES FROM FREEMAN, YOU AGREE TO BE BOUND BY ALL TERMS & CONDITIONS INCLUDED IN YOUR SERVICE MANUAL.

EXHIBITOR NAME: (PLEASE PRINT)

EXHIBITOR SIGNATURE:

DATE:

### EXHIBITING COMPANY INFORMATION

EXHIBITING COMPANY NAME:

BOOTH #:

EXHIBITING COMPANY ADDRESS:

CITY/STATE/ZIP:

PHONE:

EXT:

FAX:

CONTACT'S E-MAIL:

### Indicate which services are to be invoiced to the Third Party:

- |   |   |
|---|---|
| <input type="checkbox"/> ALL FREEMAN SERVICES       | <input type="checkbox"/> FREEMAN EXHIBIT TRANSPORTATION |
| <input type="checkbox"/> I&D LABOR/SUPERVISION      | <input type="checkbox"/> RENTAL FURNITURE/CARPET/SIGNS  |
| <input type="checkbox"/> MATERIAL HANDLING/IN & OUT | <input type="checkbox"/> BOOTH CLEANING                 |
|   | <input type="checkbox"/> OTHER _____                    |

### THIRD PARTY COMPANY INFORMATION

THIRD PARTY COMPANY NAME:

CONTACT NAME:

THIRD PARTY BILLING ADDRESS:

CITY/STATE/ZIP:

PHONE:

EXT:

FAX:

CONTACT'S E-MAIL:

E-MAIL FOR INVOICE:

Invoices will be sent by e-mail; please provide the e-mail address of the person who reconciles your invoices if different than contact's e-mail.

### THIRD PARTY CREDIT/DEBIT CARD AUTHORIZATION

- AMERICAN EXPRESS    MASTERCARD    VISA   **We do not accept credit card information via email.**

ACCOUNT NO:

EXP. DATE:

CARDHOLDER NAME (PLEASE PRINT):

CARD TYPE:

AUTHORIZED SIGNATURE:

CARDHOLDER BILLING ADDRESS:

CITY/STATE/ZIP:

01/17 (435539)

FREEMAN third party authorization

# PAYMENT & LABOR

## YOU ARE ENTERING A CONTRACT WHICH LIMITS YOUR POSSIBLE RECOVERY IN CASE OF LOSS OR DAMAGE.

The terms and conditions set forth below become a part of the Contract between FREEMAN and you, the EXHIBITOR. Acceptance of said terms and conditions will be construed when any of the following conditions are met:

- THE METHOD OF PAYMENT FORM IS SIGNED; OR
- AN ORDER FOR LABOR, SERVICES AND/OR RENTAL EQUIPMENT IS PLACED BY EXHIBITOR WITH FREEMAN; OR
- WORK IS PERFORMED ON BEHALF OF EXHIBITOR BY LABOR SECURED THROUGH FREEMAN.

## DEFINITIONS

For purposes of this Contract, "FREEMAN" or "The Freeman Companies" means Freeman Expositions, Inc., Freeman Expositions, Ltd., Freeman Audio Visual, Freeman Exhibit, Freeman Transportation, Hoffend Xposition, Stage Rigging, Inc., Kerry Technical Services, TFC, Inc., Freeman Electrical Services, and their respective employees, directors, officers, agents, assigns, affiliated companies, and related entities including, but not limited, to any subcontractors FREEMAN may appoint. The term "EXHIBITOR" means the Exhibitor, its employees, agents, representatives, and any Exhibitor Appointed Contractors ("EAC").

## PAYMENT TERMS

Full payment, including any applicable tax, is due in advance or at show site. All payments must be in U.S. funds and all checks must be drawn on a U.S. bank. Orders received without advance payment or after the deadline date will incur additional After Deadline charges as indicated on each order form. All materials and equipment are on a rental basis for the duration of the show or event and remain the property of FREEMAN except where specifically identified as a sale. All rentals include delivery, installation, and removal from EXHIBITOR'S booth. In case of cancellation of any orders or services by EXHIBITOR, a one-hour "per person, per hour" charge will be applied for all labor orders that are not canceled in writing at least 24 hours prior to the scheduled start time. If Prestige Carpet, Custom-Cut Carpet, Modular Rental Exhibits and any other custom-order items or services have already been provided at the time of cancellation, fees will remain at 100% of the original charge. If the Show or Event is canceled because of reasons beyond FREEMAN'S control, EXHIBITOR remains responsible for all charges for services and equipment provided up to and including the date of cancellation. FREEMAN will not issue refunds to EXHIBITOR of any payments made before the date of cancellation. It is EXHIBITOR'S responsibility to advise the FREEMAN Service Center Representative of problems with any orders, and to check the EXHIBITOR'S invoice for accuracy prior to the close of the Show or Event. If EXHIBITOR is exempt from payment of sales tax, FREEMAN requires an exemption certificate for the State in which the services are to be used. Resale certificates are not valid unless EXHIBITOR is rebilling these charges to its customers. For International EXHIBITORS, FREEMAN requires 100% prepayment of advance orders, and any order or services placed at show site must be paid at the show. For all others, should there be any pre-approved unpaid balance after the close of the show; terms will be net, due and payable in DALLAS, TEXAS upon receipt of invoice. Effective 30 days after invoice date, any unpaid balance will bear a FINANCE CHARGE at the lesser of the maximum rate allowed by applicable law, or 1.5% per month, which is an ANNUAL PERCENTAGE RATE of 18%, and future orders will be on a prepaid basis only. If any finance charge hereunder exceeds the maximum rate allowed by applicable law, the finance charge shall automatically be reduced to the maximum rate allowed, and any excess finance charge received by FREEMAN shall be either applied to reduce the principal unpaid balance or refunded to the payer. If past due invoices or invoice balances are placed with a collection agency or attorney for collection or suit, EXHIBITOR agrees to pay all legal and collection costs. THESE PAYMENT TERMS AND CONDITIONS SHALL BE GOVERNED BY AND CONSTRUED IN ACCORDANCE WITH THE LAWS OF THE STATE OF TEXAS. In the event of any dispute between the EXHIBITOR and FREEMAN relative to any loss, damage, or claim, such EXHIBITOR shall not be entitled to and shall not withhold payment, or any partial payment, due to FREEMAN for its services, as an offset against the amount of any alleged loss or damage. Any claims against FREEMAN shall be considered a separate transaction, and shall be resolved on its own merits. FREEMAN reserves the right to charge EXHIBITOR for the difference between the estimate of charges and the actual charges incurred for material handling, labor time & materials, utility services or equipment usage, or for any charges that FREEMAN may be obligated to pay on behalf of EXHIBITOR, including without limitation, any shipping charges. If EXHIBITOR provides a credit card for payment and charges are rejected by the EXHIBITOR'S credit card company for any reason, FREEMAN hereby provides notice that it reserves the right, and EXHIBITOR authorizes FREEMAN, to continue to attempt to secure payment through that credit card for as long as unpaid balances remain on the EXHIBITOR'S account. In the event that a THIRD PARTY orders on behalf of the EXHIBITOR and the named THIRD PARTY does not discharge payment of the invoice prior to the last day of the show, charges will revert back to the EXHIBITOR. All invoices are due and payable upon receipt, by either party.

## ELECTRICAL

Claims will not be considered, or adjustments made unless filed in writing, by Exhibitor, prior to the close of the event. Freeman is not responsible for any damage or loss caused by the loss of power beyond its control and Exhibitor agrees to hold Freeman, its officers, directors, employees and agents harmless from such power loss. IN NO EVENT SHALL FREEMAN BE LIABLE FOR ANY INDIRECT OR CONSEQUENTIAL DAMAGES (INCLUDING WITHOUT LIMITATION LOST PROFITS) EVEN IF ADVISED OF THE POSSIBILITY OF SUCH DAMAGES, WHETHER UNDER THEORY OF CONTRACT, TORT (INCLUDING NEGLIGENCE), PRODUCTS LIABILITY OR OTHERWISE. Exhibitor shall indemnify and hold harmless Freeman, its officers, directors, employees, and agents from and against any and all claims, liabilities, damages, fines, penalties or costs of whatsoever nature (including reasonable attorneys' fees) arising out of or in any way connected with Exhibitor's actions or omissions under this Agreement.

## LABOR UNDER THE SUPERVISION OF EXHIBITOR RESPONSIBILITIES

EXHIBITOR shall be responsible for the performance of labor provided under this option. It is the responsibility of EXHIBITOR to supervise labor secured through FREEMAN in a reasonable manner as to prevent bodily injury and/or property damage and also to direct them to work in a manner that is in compliance with FREEMAN'S Safe Work Rules and/or Federal, State, County and Local ordinances, rules and/or regulations, including but not limited to Show or Facility Management rules and/or regulations. It is the responsibility of EXHIBITOR to check in with the Service Desk to pick up labor, and to return to the Service Desk to release labor when the work is completed.

## INDEMNIFICATION

EXHIBITOR agrees to indemnify, hold harmless, and defend FREEMAN from and against any and all demands, claims, causes of action, fines, penalties, damages, liabilities, judgments, and expenses (including but not limited to reasonable attorneys' fees and investigation costs) for bodily injury, including any injury to FREEMAN employees, and/or property damage arising out of work performed by labor provided by FREEMAN but supervised by EXHIBITOR. Further, the EXHIBITOR'S indemnification of FREEMAN includes any and all violations of Federal, State, County or Local ordinances, "Show Regulations and/or Rules" as published and/or set forth by Facility or Show Management, and/or directing labor provided by FREEMAN to work in a manner that violates any of the above rules, regulations, and/or ordinances.

## IMPORTANT

PLEASE REFER TO FREEMAN'S "MATERIAL HANDLING TERMS & CONDITIONS" AS IT RELATES TO MATERIAL HANDLING SERVICES AND TO THE "SERVICE REQUEST & SHIPPING INSTRUCTIONS CONTRACT" AS IT RELATES TO TRANSPORTATION SERVICES. CONTRACT TERMS DEPEND ON THE NATURE OF SERVICES SECURED BY EXHIBITOR THROUGH FREEMAN. TERMS & CONDITIONS MAY VARY FOR EACH TYPE OF SERVICE ORDERED THROUGH FREEMAN.



# MATERIAL HANDLING

**YOU ARE ENTERING A BINDING CONTRACT WHICH LIMITS YOUR POSSIBLE RECOVERY IN CASE OF LOSS OR DAMAGE.** Acceptance of said terms and conditions will be construed when any of the following conditions are met: This Material Handling Agreement (MHA) is signed; Exhibitor's materials are delivered to Freeman's warehouse or to an event site for which Freeman is the Official Show Contractor; or an order for labor and/or rental equipment is placed by Exhibitor with Freeman. Please be aware that disposal of exhibit properties is not included as part of your material handling charges. Please contact freeman for your quoted rates and rules applicable to disposal of your exhibit properties.

**1. DEFINITIONS.** For purposes of this Contract, Freeman means Freeman Expositions, Inc., and its employees, directors, officers, agents, assigns, affiliated companies, and related entities. In no event shall Freeman be deemed to be the Ultimate Consignee for shipping and custom purposes. The term "Exhibitor" means the Exhibitor, its employees, agents, and representatives.

**2. PACKAGING/CRATES AND STORAGE.** Freeman shall not be responsible for damage to loose or uncrated materials, pad wrapped or shrink-wrapped materials, glass breakage, concealed damage, carpets in bags or poly, or improperly packed or labeled materials. Freeman shall not be responsible for crates and packaging which are unsuitable for handling, in poor condition, or have prior damage. Crates and packaging should be of a design to adequately protect contents for handling by forklift and similar means. Freeman does not accept any crates or packaging containing hazardous materials. Goods requiring cold storage and those in accessible storage are stored at Exhibitor's own risk. **FREEMAN ASSUMES NO RESPONSIBILITY OR LIABILITY FOR LOSS OR DAMAGE TO GOODS IN COLD STORAGE OR ACCESSIBLE STORAGE.**

**3. EMPTY CONTAINERS.** Empty container labels will be available at the show site service desk. Affixing labels to the containers is the sole responsibility of Exhibitor or its representative. All previous labels must be removed or obliterated. Freeman assumes no responsibility for: error in the above procedures; removal of containers with old empty labels and without Freeman labels; or improper information on empty labels. **FREEMAN WILL NOT BE LIABLE FOR LOSS OR DAMAGE TO CRATES AND CONTAINERS OR THEIR CONTENTS WHILE SAME ARE IN EMPTY CONTAINER STORAGE.**

**4. INBOUND/OUTBOUND SHIPMENTS.** There may be a lapse of time between the delivery of shipment(s) to the booth and the arrival of Exhibitor, or a lapse of time between the completion of packing and the actual pickup of materials from the booths for loading onto a carrier and during such times, Exhibitor materials will be left unattended. **FREEMAN IS NOT RESPONSIBLE OR LIABLE FOR ANY LOSS, DAMAGE, THEFT, OR DISAPPEARANCE OF EXHIBITOR'S MATERIALS AFTER THEY HAVE BEEN DELIVERED TO EXHIBITOR'S BOOTH AT SHOW SITE OR BEFORE THEY HAVE BEEN PICKED UP FOR RELOADING AT THE CONCLUSION OF THE EVENT.** Freeman recommends the securing of security services from Facility or Show Management. All MHA's submitted to Freeman by Exhibitor will be checked at the time of pickup from the booth and corrections will be made where discrepancies exist between the quantities of items on any form submitted to Freeman and the actual count of such items in the booth at the time of pickup. Freeman is not responsible for any wait time or other charges including business center charges arising from delivery or pickup of Exhibitor's materials.

**5. DELIVERY TO THE CARRIER FOR RELOADING.** Freeman assumes no responsibility for loss, damage, theft, or disappearance of Exhibitor's materials after same have been delivered to Exhibitor's appointed carrier, shipper, or agent for transportation after the conclusion of the show. Freeman loads the materials onto the carrier under directions from the carrier or driver of that carrier. Any loading onto the carrier will be understood to be under the exclusive supervision and control of the carrier or driver of that carrier. **FREEMAN ASSUMES NO RESPONSIBILITY FOR LOSS, DAMAGE, THEFT OR DISAPPEARANCE OF EXHIBITOR'S MATERIALS THAT ARISES OUT OF IMPROPERLY LOADED OR LABELED MATERIALS.**

**6. DESIGNATED CARRIERS.** Freeman shall have the authority to change the Exhibitor designated carrier if that carrier does not pick up the shipment(s) at the appointed time. Where no disposition is made by Exhibitor, materials may be taken to a warehouse to await Exhibitor's shipping instructions and Exhibitor agrees to be responsible for charges relating to such rerouting and handling. **IN NO EVENT SHALL FREEMAN BE RESPONSIBLE FOR ANY LOSS RESULTING FROM SUCH REROUTING DESIGNATION.**

**7. FORCE MAJEURE.** Freeman's performance hereunder is subject to, and Freeman shall not be responsible for loss, delay, or damage due to, strike, work stoppages, natural elements, vandalism, Act of God, civil disturbances, power failures, explosions, acts of terrorism or war, or for any other cause beyond Freeman's reasonable control, nor for ordinary wear and tear in the handling of Exhibitor's materials.

**8. CLAIM(S) FOR LOSS.** Exhibitor agrees that any and all claims for loss or damage must be submitted to Freeman immediately at the show site and in any case not later than **thirty (30) business days** after the date when Exhibitor's materials are delivered to the carrier for transportation from show site or from Freeman's warehouse. All claims reported after thirty (30) days will be rejected. In no event shall a suit or action be brought against Freeman **more than one (1) year** after the date of loss or damage occurred.

**a. PAYMENT FOR SERVICES MAY NOT BE WITHHELD.** In the event of any dispute between the Exhibitor and Freeman relative to any loss, damage, or claim, Exhibitor shall not be entitled to and shall not withhold payment due Freeman for its services as an offset against the amount of any alleged loss or damage. Any claims against Freeman shall be considered a separate transaction and shall be resolved on their own merits.

**b. MAXIMUM RECOVERY.** If found liable for any loss, Freeman's sole and exclusive maximum liability for loss or damage to Exhibitors materials and Exhibitor's sole and exclusive remedy is limited to \$50 (USD) per pound per article with a maximum liability of \$100.00 (USD) per item, or \$1,500.00 (USD) per shipment whichever is a less. For unmarked, unlabeled and improperly packaged television monitors, the maximum liability is the lesser of \$3.00 (USD) per pound or the actual invoice price. All shipment weights are subject to correction and final charges determined by the actual or re-weighed weight of the shipment.

**c. LIMITATION OF LIABILITY.** IN NO EVENT SHALL FREEMAN BE LIABLE TO THE EXHIBITOR OR TO ANY OTHER PARTY FOR SPECIAL, COLLATERAL, EXEMPLARY, INDIRECT, INCIDENTAL, OR CONSEQUENTIAL DAMAGES, WHETHER SUCH DAMAGES OCCUR EITHER PRIOR OR SUBSEQUENT TO, OR ARE ALLEGED AS A RESULT OF, TORTIOUS CONDUCT, FAILURE OF THE EQUIPMENT OR SERVICES OF FREEMAN OR BREACH OF ANY OF THE PROVISIONS OF THIS CONTRACT, REGARDLESS OF THE FORM OF ACTION, WHETHER IN CONTRACT OR IN TORT, INCLUDING STRICT LIABILITY AND NEGLIGENCE, EVEN IF FREEMAN HAS BEEN ADVISED OR HAS NOTICE OF THE POSSIBILITY OF SUCH DAMAGES. SUCH EXCLUDED DAMAGES INCLUDE BUT ARE NOT LIMITED TO LOST PROFITS, LOSS OF USE, AND INTERRUPTION OF BUSINESS OR OTHER CONSEQUENTIAL OR INDIRECT ECONOMIC LOSSES.

**9. DECLARED VALUE.** Declarations of Declared Value are between the Exhibitor and the selected Carrier ONLY, and are in no way an extension of Freeman's maximum liability stated herein. Freeman will use commercially reasonable efforts to transmit the Declared Value instructions to the selected Carrier; however, FREEMAN WILL NOT BE LIABLE FOR ANY CLAIM ARISING FROM THE TRANSMITTAL OF, OR FAILURE TO TRANSMIT, DECLARED VALUE INSTRUCTIONS TO THE CARRIER NOR FOR FAILURE OF THE CARRIER TO UPHOLD THE DECLARED VALUE OR ANY OTHER TERM OF CARRIAGE.

**10. JURISDICTION / VENUE.** THIS CONTRACT SHALL BE CONSTRUED UNDER THE LAWS OF THE STATE OF TEXAS WITHOUT GIVING EFFECT TO ITS CONFLICT OF LAWS RULES. EXCLUSIVE VENUE FOR ALL DISPUTES ARISING OUT OF OR RELATING TO THIS CONTRACT SHALL RESIDE IN A COURT OF COMPETENT JURISDICTION IN DALLAS COUNTY, TEXAS.

**11. INDEMNIFICATION.** Exhibitor agrees to indemnify and forever hold harmless Freeman from and against any and all demands, claims, causes of action, fines, penalties, damages (including consequential), liabilities, judgments, and expenses (including but not limited to reasonable attorneys' fees and investigation costs) arising out or contributed to by Exhibitor's negligent supervision of any labor secured through Freeman; Exhibitor's negligence, willful misconduct, or deliberate act, or the negligence, willful misconduct, or deliberate act of Exhibitor's employees, agents, representatives, customers, invitees and/or any Exhibitor Appointed Contractors (EAC) at the show or event to which this Contract relates, including but not limited to Exhibitor's violation of Federal, State, County or Local ordinance and/or Exhibitor's violation of Show Regulations and/or Rules as published and set forth by Facility and/or Show Management.

**12. LIEN.** Exhibitor grants Freeman a security interest in and a lien on all of Exhibitor's materials that is from time to time in the possession of Freeman and all the proceeds thereof, including without limitation insurance proceeds (the "Collateral"), to secure the prompt and full payment and performance of all Exhibitor's indebtedness for monies paid, by Freeman on its behalf, services performed, materials and/or labor from time to time provided by Freeman to or for the benefit of Exhibitor ("Obligations"). Freeman shall have all the rights and remedies of a secured party under the Uniform Commercial Code, as may be amended from time to time ("UCC"), and any notice that Freeman is required to give under the UCC of a time and place of a public sale or the time after which any private sale or other intended disposition of any Collateral is to be made shall be deemed to constitute reasonable notice if such notice is mailed by registered or certified mail at least five (5) days prior to such action. Freeman may hold and not deliver any of the Collateral to Exhibitor for so long as there are any Obligations that remain unpaid or unsatisfied.

**13. WAIVER & RELEASE.** Exhibitor, as a material part of the consideration to Freeman for material handling services, waives and releases all claims against Freeman with respect to all matters for which Freeman has disclaimed liability pursuant to the provisions of this Contract.

**14. DRIVER LIABILITY WAIVER.** IN CONSIDERATION OF FREEMAN PERMITTING ENTRANCE TO THE PREMISES, YOU, YOUR EMPLOYER, THE OWNER OF THE TRUCK AND/OR EQUIPMENT THAT YOU ARE OPERATING (TRUCKOWNER) AND YOU AS AGENT OF YOUR EMPLOYER AND THE TRUCKOWNER, HEREBY ASSUME ALL RISK OF INJURY OR HARM TO YOURSELF AND OTHERS AND DAMAGE TO YOUR PROPERTY AND PROPERTY BELONGING TO YOUR EMPLOYER OR OTHERS ARISING FROM YOUR ACTIVITIES WHILE BEING PERMITTED TO ENTER THE PREMISES. YOU AGREE TO ENTER AT YOUR OWN RISK. YOU HAVE FULL KNOWLEDGE OF ANY RISK INVOLVED IN THIS ACTIVITY. YOU RECOGNIZE THE HAZARDS AND ARE AWARE OF ALL THE RULES FOR SAFE OPERATION. YOUR EMPLOYER, THE TRUCKOWNER, AND YOU AGREE TO INDEMNIFY AND HOLD HARMLESS FREEMAN, ITS EMPLOYEES, OFFICERS, DIRECTORS, AGENTS, ASSIGNS, AFFILIATED COMPANIES AND RELATED ENTITIES, AGAINST ANY AND ALL LIABILITY, ACTIONS, CLAIMS, AND DAMAGES OF ANY KIND WHATSOEVER ARISING FROM YOUR ACTIVITIES WHILE BEING PERMITTED TO ENTER THE PREMISE.

# AIR CARGO

## AIR CARGO SERVICE REQUEST AND SHIPPING INSTRUCTIONS CONTRACT

In tendering this shipment, the Shipper and Consignee agree to these TERMS which no agent or employee of the parties may alter. This Air Service Request and Shipping Instruction Contract is NON-NEGOTIABLE and has been prepared by Shipper, or if by Freeman or another on Shipper's behalf, it shall be deemed, conclusively, to have been prepared by the Shipper. The Shipper agrees that this shipment is subject to the TERMS stated herein All TERMS, including but not limited to, all the limitations of liability, shall apply to our agents and their contracting carriers.

**1. DEFINITIONS:** In this Contract, "Freeman" means Freeman Decorating Services, Inc., and its respective employees, officers, directors, agents, assigns, affiliated companies, and related entities including any contractors appointed by Freeman. The term "Shipper" means the person or business for whom the property is being transported, and includes their respective employees, officers, directors, agents, assigns, affiliated companies, and contractors appointed by the Shipper, excluding only Freeman. "Property" is all objects of any type received from the Shipper for transport by Freeman as described herein. "Consignee" is the party to whom Shipper has designated the goods are to be delivered.

**2. FINAL CONTRACT BETWEEN THE PARTIES:** In exchange for Shipper's payments and Freeman's services, which the parties have specified in this two-page Contract (including the Air Cargo Service Request and Shipping Instructions), Freeman and Shipper each agree that this Contract shall govern their respective rights and obligations regarding transportation of Shipper's property. This Contract shall take effect when the property first comes into the physical possession of Freeman, and the responsibility of Freeman under same shall end when the property has been placed in the possession of the Consignee or the Consignee's designated agent. If any part or provision of this Contract is found by a court of competent jurisdiction to be void or unenforceable, the remainder of the Contract shall continue in full force and effect.

**3. Freeman's RESPONSIBILITIES UNDER THE CONTRACT ARE LIMITED:** Freeman is responsible for the satisfactory performance of only those services which it directly provides under this Contract. Freeman shall not be responsible for the performance of individuals of firms who are not under the direct supervision or control of Freeman. Freeman shall not be responsible for events or causes of loss, delay, or damage beyond its reasonable control, including (by way of illustration only, and not as a limitation on the breadth of this clause), strike, lockout, work slowdown or stoppage, power failure, breakdown of plant or machinery, facility failure, vandalism, theft, Act of God, effect of natural elements, riot, civil commotion or disturbance, terrorism, act of war or belligerent parties, and any other cause or causes beyond the reasonable control of Freeman. EXCEPT FOR ELIGIBLE GUARANTEED SERVICE SHIPMENTS, Freeman DOES NOT GUARANTEE DELIVERY BY ANY SPECIFIC TIME OR DATE.

**4. PACKAGING AND CRATES:** Shipper's property must be well packaged for safe and secure handling, storage and shipment using ordinary care. Each piece must be legibly and durably marked with the name and address, including correct ZIP code of the Shipper and Consignee. When a container is used repeatedly by Shipper, Shipper must remove all old labels, tags, markings, etc., and Shipper must ensure that the container retains adequate strength for transportation. Freeman makes neither representation nor any warranty regarding the acceptability or suitability of any packaging system or procedure that Shipper might use for its property. Freeman shall not be responsible for damage to loose or uncrated materials, padwrapped or shrink-wrapped materials, glass breakage, concealed damage, carpets in bags or poly, or improperly packed or labeled materials. Crates and packaging should be of a design to adequately protect contents for handling by forklift and similar means. General guidance as to acceptable packaging systems and procedures may be found in publications such as the National Motor Freight Classification, published by the National Motor Freight Traffic Association. For shipments of Perishable Commodities, U.S. and Canadian shipments must be packed to travel without spoilage for 72 hours from time of pickup; all International shipments must be packed to travel without spoilage for 24 hours beyond an agreed deadline. Freeman reserves the right to periodically embargo regions of the world due to conditions that may cause damage to perishable commodities. If the integrity of a shipment is in question, Freeman reserves the right to improve packaging at shipper's expense.

**5. REFUSED SHIPMENTS:** If the Consignee refuses a shipment tendered for delivery or if Freeman is unable to deliver a shipment because of fault or mistake of the Consignor or Consignee, Freeman's liability shall then become that of a warehouseman.

(a) Freeman shall promptly attempt to provide notice, by telephonic, electronic or written communication as provided on the face of these shipping instructions, if so indicated, to Shipper or the party, if any, designated to receive notice in these instructions.

(b) Storage charges, based on Freeman's applicable rates, shall start no sooner than the next business day following the attempted notification. Storage may be, at Freeman's option, in any location that provides reasonable protection against loss or damage. Freeman may place the shipment in public storage at the owner's expense and without liability to Freeman.

(c) If Freeman does not receive disposition instructions within 48 hours of the time of Freeman's attempted first notification, Freeman will attempt to issue a second and final confirmed notification. Such notice shall advise that if Freeman does not receive disposition instructions within 10 days of that notification, Freeman may offer the shipment for sale at a public auction and Freeman has the right to offer the shipment for sale. The amount of sale will be applied to Freeman's invoice for transportation, storage and other lawful charges. Shipper will be responsible for the balance of charges not covered by the sale of the goods. If there is a balance remaining after all charges and expenses are paid, such balance will be paid to the owner of the property sold hereunder, upon claim and proof of ownership.

(d) Where Freeman has attempted to follow the procedure set forth above and the procedure is not possible, nothing shall be construed to abridge the right of Freeman, at its option, to sell the property under such circumstances and in such manner as may be authorized by law.

(e) When perishable goods cannot be delivered and disposition is not given within a reasonable time, Freeman may dispose of property to the best advantage. Where Freeman is directed by Consignee or Consignor to unload or deliver property at a particular location where Consignor, Consignee, or the Agent of either is not regularly located, Freeman's liability for the shipment shall terminate after unloading or delivery.

**6. LIMITATION ON SHIPPER'S RECOVERABLE DAMAGES:** FREEMAN'S LIABILITY FOR DAMAGES ON DOMESTIC SHIPMENTS, INCLUDING BUT NOT LIMITED TO THOSE DAMAGES ARISING FROM OR RELATED TO MISDELIVERY, INCOMPLETE OR OTHERWISE INADEQUATE DELIVERY (INCLUDING BUT NOT LIMITED TO FAILURE TO FOLLOW SHIPPER OR CONSIGNEE INSTRUCTIONS OR FAILURE TO COLLECT OR PROPERLY DELIVER A PAYMENT INSTRUMENT), NONDELIVERY, MISSED PICKUP, AND LOSS OF OR DAMAGE TO CARGO, SHALL BE LIMITED TO THE HIGHER OF \$50.00 (USD) PER SHIPMENT OR \$.50 (USD) PER POUND (\$1.10 (USD) PER KILOGRAM) OF CARGO ADVERSELY AFFECTED THEREBY, PLUS TRANSPORTATION CHARGES APPLICABLE TO THAT PART OF THE SHIPMENT ADVERSELY AFFECTED THEREBY, UNLESS AT TIME OF SHIPMENT THE SHIPPER MAKES A DECLARATION OF VALUE FOR CARRIAGE IN THE SPACE DESIGNATED ON THE SERVICE REQUEST AND SHIPPING INSTRUCTIONS FORM AND PAYS THE APPROPRIATE VALUATION CHARGE. IN NO EVENT SHALL FREEMAN'S LIABILITY EXCEED THE DECLARED VALUE OF THE SHIPMENT OR THE AMOUNT OF LOSS OR DAMAGE ACTUALLY SUSTAINED, WHICHEVER IS LOWER. IF CARRIAGE OF THE SHIPMENT IS SOLELY OR PARTLY BY AIR AND INVOLVES AN ULTIMATE DESTINATION OR A STOP IN A COUNTRY OTHER THAN THE COUNTRY OF DEPARTURE, Freeman's LIABILITY FOR CARGO LOST, DAMAGED OR DELAYED SHALL BE LIMITED TO \$9.07 PER POUND (\$20.00 PER KILOGRAM) FOR CARRIAGE SUBJECT TO THE UNAMENDED WARSAW CONVENTION OR THE WARSAW CONVENTION AS AMENDED BY THE HAGUE PROTOCOL OF 1955, 17 SPECIAL DRAWING RIGHTS PER KILOGRAM FOR CARRIAGE SUBJECT TO THE WARSAW CONVENTION AS AMENDED BY THE MONTREAL PROTOCOL NO. 4 OF 1975, OR \$9.07 PER POUND (\$20.00 PER KILOGRAM) FOR CARRIAGE WHERE THE WARSAW CONVENTION, INCLUDING ITS AMENDMENTS, DOES NOT APPLY FOR ANY REASON, UNLESS A HIGHER DECLARED VALUE IS REQUESTED, AND THE FEES SET FORTH IN THE SERVICE GUIDE FOR SUCH HIGHER DECLARED VALUE ARE PAID. FOR INTERNATIONAL SHIPMENTS, THIS SHIPPING REQUEST AND SHIPPING INSTRUCTION CONTRACT SHALL BE DEEMED AN AIR WAYBILL WITHIN THE MEANING OF THE WARSAW CONVENTION.

Notwithstanding the above limitations, domestic shipments containing the following items of extraordinary value are limited to a maximum declared value of \$500.00 (USD):

(a) artworks and objects of art, including without limitation original paintings, drawings, etchings, water colors, tapestries and sculpture;

(b) clocks, watches, jewelry (including costume jewelry), furs and fur-trimmed clothing;

(c) personal effects;

(d) and other inherently fragile or unique items, including prototypes, etc.

Any declared value in excess of the maximums allowed herein is null and void, and the acceptance by Freeman for carriage of any shipment with a declared value in excess of the allowed maximums does not constitute a waiver of these maximums. Shipper understands that even if Shipper is not able to participate or fully participate in a show due to loss of, theft of, or damage to its property, Freeman shall never be liable or responsible for damages identified by the terms (by way of example only and not in limitation of the breadth of this clause) such as the following: consequential damages, loss of use damages, loss of profits damages, business interruption damages, delay damages, special damages, collateral damages, exemplary damages, damages awarded for gross negligence, direct damages, indirect damages, damages for failure of performance, breach of contract damages, fraud damages, or any other sort of damage for tort or breach of contract. This limitation shall bind the parties:

(a) whenever or wherever the claimed loss or damage may occur;

(b) even though the alleged loss or damage is claimed to result from negligence, strict liability, products liability, breach of contract, breach of statute or regulation, or any other legal theory or cause, and;

(c) even though Freeman may have been advised or be on notice of the possibility or even the probability of such damages. Freeman makes no warranties, express or implied, and expressly disclaims any and all warranties. Except for Freeman's failure to deliver in accordance with the Guaranteed Service section of the Service Guide, Freeman will not be liable for misdelivery, incomplete or otherwise inadequate delivery (including but not limited to failure to follow Shipper or Consignee instructions or failure to collect or properly deliver a payment instrument), non-delivery, missed pickup, delay on International shipments, loss or damage unless caused by Freeman's sole negligence.

### 7. SHIPPER'S RESPONSIBILITIES AND INDEMNIFICATION:

(a) Shipper must pay in full for the services rendered under this Contract at the time the services are requested. The existence of a dispute between Shipper and Freeman relative to any claim or other matter shall have no bearing on this duty of payment. No claim submitted by or on behalf of Shipper will be processed unless Shipper's account is current.

(b) Shipper understands and acknowledges that Freeman does not accept or transport illegal, dangerous or hazardous materials of any kind or nature. Shipper warrants and ensures that its property is inert, and contains no Hazardous Substances, Hazardous Materials, Chemicals, Gases, Explosives, Radioactive Materials, Biologically hazardous agents, or any other substance, matter or object in any form that could pose a threat to the health or safety of persons, property or the public welfare in general. Such goods may be warehoused at owner's risk and expense or destroyed without compensation.

(c) Shipper shall defend and indemnify Freeman, its employees, directors, officers, and agents from and against any and all demands, claims, causes of action, fines, penalties, damages (including consequential), liabilities, judgments, and expenses (including but not limited to reasonable attorneys' fees and investigation costs) on account of personal injury, death, or damage to or loss of property or profits arising out of or contributed to by any of the following: Shipper's negligence, willful misconduct, or deliberate act; Shipper's violation of Federal, State, County or Local ordinances; Shipper's violation of Show Regulations and/or Rules as published and set forth by Facility and/or Show Management; and/or Shipper's failure to comply with (b) of this Agreement regarding the inclusion of any dangerous substances in the property placed with Freeman.

**8. CLAIMS:** Shipper, Consignee, or any other party claiming an interest in the shipment must notify Freeman immediately upon delivery, or in the case of loss or damage which could not have been noted at the time of delivery, within five (5) business days of delivery, of any loss or damage to the shipment. Notice of concealed damage must be confirmed in writing or via e-mail at [exhibit.transportation@freeman.com](mailto:exhibit.transportation@freeman.com) within 5 business days of receipt of the property. If Carrier schedules an inspection, claimant must hold the shipping container, all packaging material and contents in the same condition as they were in when damage was discovered. Receipt of the shipment by the Consignee or the Consignee's agent without written notice on the delivery receipt and/or delivery manifest will be prima facie evidence that the shipment was delivered in good condition. The amount of the claim may not be deducted from the transportation charges. Notice of loss or damage MUST be reported to Freeman at 800-995-3579. The shipment, its container(s), and packing material must be made available to Freeman for inspection at the delivery location. All shipments are subject to opening for inspection by Freeman; however, Freeman is not obligated to perform such inspection. All claims for loss or damage MUST be made in writing to Freeman within one hundred and twenty (120) calendar days after the date of acceptance of the shipment by Freeman. Please refer to the Service Guide for claim procedures. All claims for service failure must be made within thirty (30) calendar days from the date of shipment and Freeman's sole liability for such claims arising from Guaranteed Service shipments shall be limited to the transportation charges as provided in the Guaranteed Service section of the Service Guide. All claims for overcharge must be made in writing to Freeman within sixty (60) calendar days after the invoice date. No action for loss or damage may be maintained against Freeman unless (a) claimant complies with all requirements of this section and (b) for domestic shipments, if the claimant commences the action within one (1) year of the shipment by Freeman unless otherwise required by International, Federal or State Law. If the claim is for loss or damage involving International shipments, claimant must commence the action within two (2) years from the date of acceptance of the shipment by Freeman unless otherwise required by International, Federal or State Law. For purposes of this section, no action shall be deemed to have commenced until receipt by Freeman of service of process of the action on Freeman. Claims for loss or damage must be delivered to the following address: Sedgwick, PO Box 14151, Lexington, KY 40512-4151.

For shipping containers designed for repeated use (tradeshow cases, totes, crates), Freeman shall have no liability for superficial damage to said containers in the form of scuffs, scratches, dents or dings. Freeman will only accept liability for "catastrophic" damage to these shipping containers (crushing, puncture, or complete destruction). Freeman's maximum liability in cases of "catastrophic" damage or total loss will be limited to a depreciated value of the container based on the time elapsed from the original purchase and the purchase price established on the provided original invoice. This maximum liability will be subject to all other applicable limits of liability such as repair costs.

**9. CHOICE OF FORUM:** THIS CONTRACT SHALL BE CONSTRUED UNDER THE LAWS OF THE UNITED STATES (INCLUDING ADOPTED INTERNATIONAL CONVENTIONS) AND THE STATE OF TEXAS WITHOUT GIVING EFFECT TO THE STATE'S CONFLICT OF LAWS RULES. FREEMAN AND SHIPPER AGREE THAT ANY CLAIM OR DISPUTE OF ANY SORT ARISING OUT OF OR IN ANY WAY RELATED TO THIS CONTRACT, ITS PERFORMANCE OR NONPERFORMANCE, OR DAMAGES ALLEGEDLY RESULTING FROM SAME WILL BE ARBITRATED IN THE CITY OF DALLAS, TEXAS, AND THE RULES OF THE AMERICAN ARBITRATION ASSOCIATION WILL APPLY. IF BINDING ARBITRATION IS UNAVAILABLE TO RESOLVE ANY CONTROVERSY AND IT IS NECESSARY TO LITIGATE THE DISPUTE, THE DISPUTE SHALL BE LITIGATED IN A COURT OF COMPETENT JURISDICTION IN DALLAS COUNTY, TEXAS.

**10. MISCELLANEOUS:** Shipper warrants the accuracy of the weight and dimension data furnished in this Contract. Shipper understands that once its property is shipped by Freeman pursuant to the instructions contained in this Contract, Shipper has no right to control the shipment; stop the shipment in transit, or divert or reschedule same, and that Shipper will have no control over the property until it is delivered pursuant to the instructions in this Contract. Shipper agrees that this Contract may be provided to any third party, including common or contract carriers of cargo by air, water, rail, or road, for the purpose of confirming the right of Freeman to control the handling of the property and all matters related to payment for the shipment.



Freeman

# TRANSPORTATION COMPLETE



Freeman's all-inclusive shipping and material handling package means transporting your exhibit materials has never been simpler or as affordable.

## Double the convenience... zero surprises.

### Package includes:

- Round trip standard ground transportation AND material handling services
- No additional fees, no surprises
- Pick-up and transportation from point of origin to either advance warehouse or show site – your choice.
- Pre-printed shipping labels & outbound paperwork

### Benefits:

- Turnkey pricing ensures precise budgeting
- No additional handling, pick-up or delivery fees
- No additional fuel surcharges or overtime surcharges
- No carrier waiting time fees
- Experienced on-site transportation reps from move-in through move-out
- All charges on your Freeman invoice
- LTL (less than truck load) shipping

**To take advantage, call 1-800-995-3579 or email [exhibit.transportation@freemanco.com](mailto:exhibit.transportation@freemanco.com) for a quote.**

\*Services apply to destinations anywhere in the Continental U.S.



**F R E E M A N**  
INNOVATION DEDICATED TO YOUR BRAND

# RESULTS, DELIVERED

---

With more than 85 years of experience in the events industry, no one understands exhibit transportation better than Freeman. Our transportation services are a seamless extension of the premium products that exhibitors around the world rely on time and time again.

Between our all-inclusive pricing and superior customer service, Freeman Exhibit Transportation is the most reliable, convenient and cost-effective solution available. Our team of experts has the ability to quickly respond to changes when necessary, remaining entirely responsive to all of your show requirements, whenever and wherever they arise.

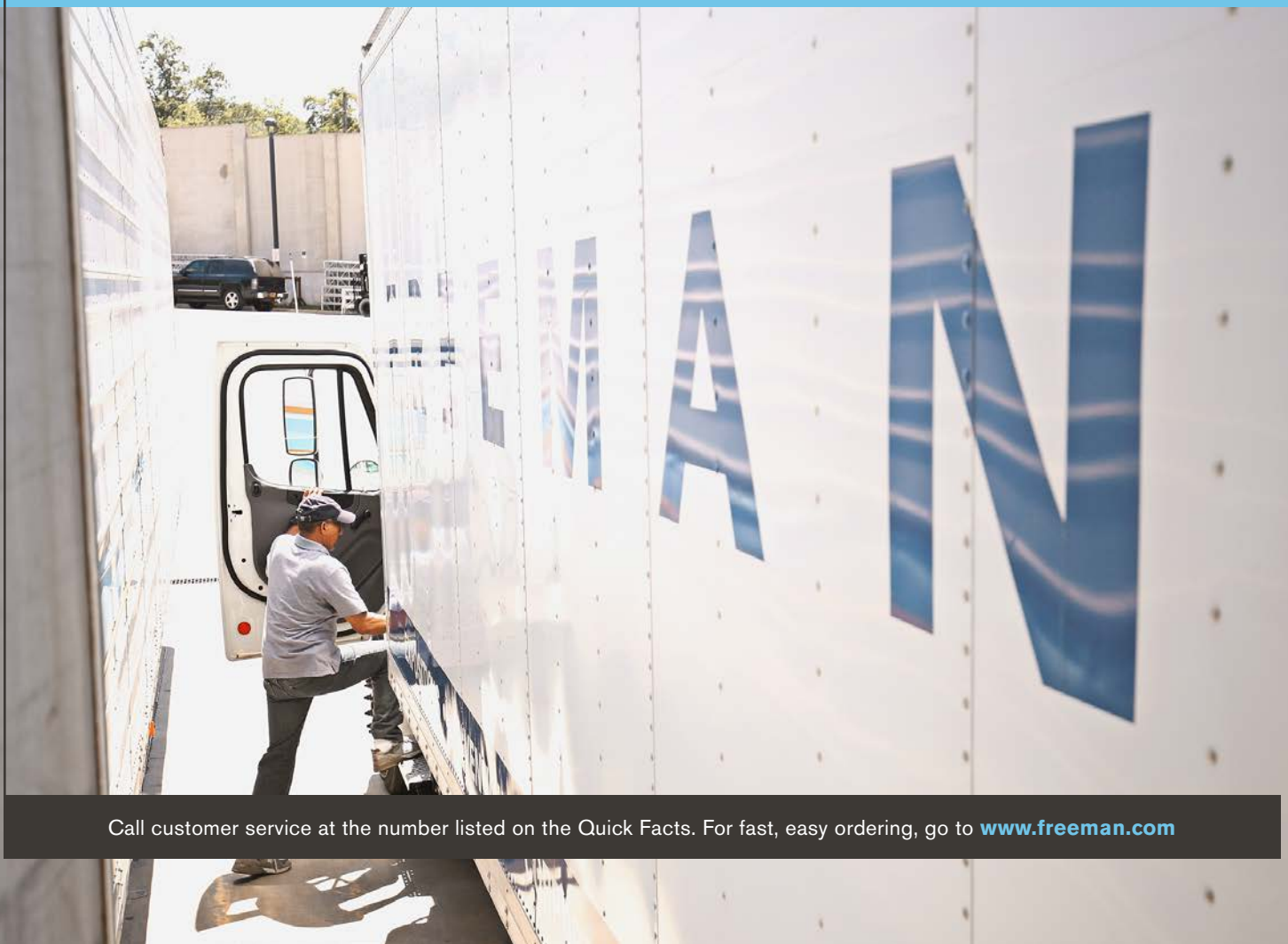

Call customer service at the number listed on the Quick Facts. For fast, easy ordering, go to [www.freeman.com](http://www.freeman.com)

## EXHIBIT TRANSPORTATION SERVICES

Freeman works directly with you and show site decision makers to transport your exhibit to any location with ease.

### The Freeman Exhibit Transportation promise:

- ALL-INCLUSIVE PRICING WITH NO ADDITIONAL FEES FOR PICKUPS AND DELIVERIES, INCLUDING WEEKEND AND NIGHT SERVICE
- ONE CONVENIENT INVOICE ENCOMPASSING ALL FREEMAN SHOW SERVICES
- ON-SITE TRANSPORTATION EXPERTS ARE AVAILABLE BEFORE, DURING AND AFTER THE SHOW
- RELIABLE CUSTOMER SERVICE SEVEN DAYS A WEEK, OFFERING COMPLETE SHIPMENT VISIBILITY AND EXPERT SUPERVISION

### questions?

For more information regarding our services, rates, shipment deadlines, documentation requirements, ordering and the terms and conditions of our service offerings, please visit [www.freeman.com](http://www.freeman.com)

Continental U.S. Exhibitors: Contact our exhibit transportation experts at **800.995.3579** or via email at [exhibit.transportation@freeman.com](mailto:exhibit.transportation@freeman.com)

International Exhibitors: Contact our exhibit transportation experts at **+1.817.607.5183** or via email at [international.freight@freeman.com](mailto:international.freight@freeman.com)

**DON'T FORGET ABOUT INBOUND SHIPPING! COMPLETE AND SEND THE ORDER FORM TO ORDER YOUR INBOUND AND OUTBOUND SHIPPING.**

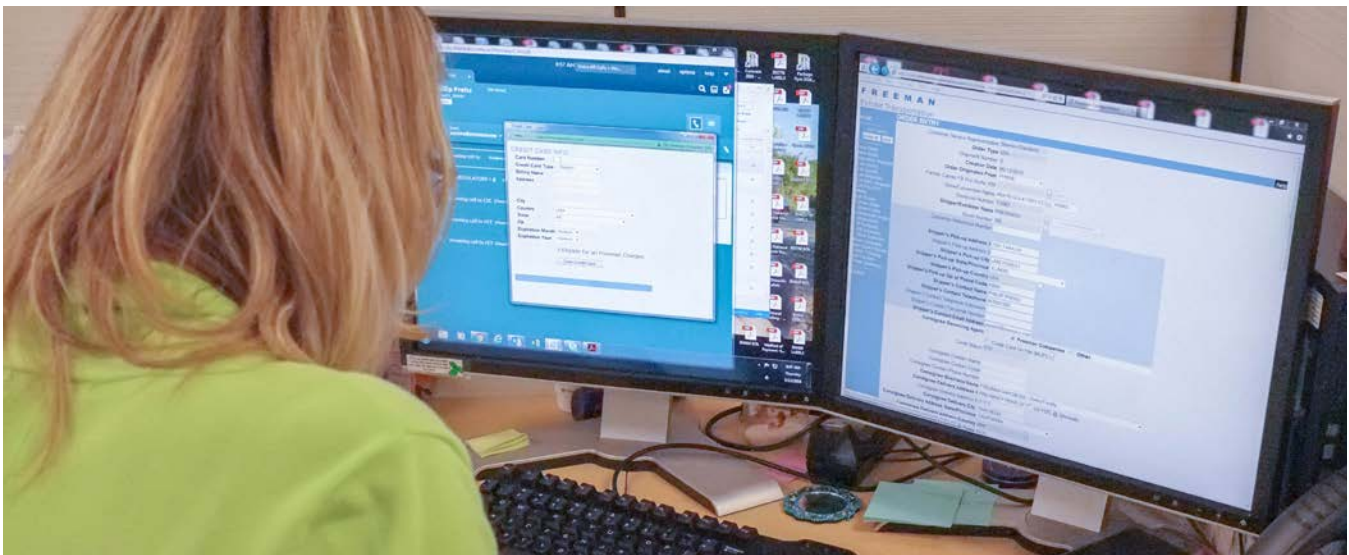

# FREEMAN

(800) 995-3579 Toll Free US & Canada  
(817) 607-5100 Local & International

**COMPLETE THIS FORM ONLY IF YOU ARE SHIPPING YOUR EXHIBIT MATERIALS BY FREEMAN EXHIBIT TRANSPORTATION**

NAME OF SHOW: **IBTTA 85th ANNUAL MEETING / SEPTEMBER 10 - 13, 2017**

COMPANY NAME:	BOOTH #:	BOOTH SIZE:	X
CONTACT NAME :	PHONE #:		
E-MAIL ADDRESS :			

For Assistance, please call applicable number listed above to speak with one of our experts.

For fast, easy ordering, go to [www.freeman.com](http://www.freeman.com)

## EXHIBIT TRANSPORTATION

### TIPS FOR EASY ORDERING

- Credit card information must be on file prior to pick up, as charges will be included on your show services invoice.
- International Exhibitors remember - Shipments originating from countries other than the U.S. must be cleared through customs. Please call for additional information:  
(800) 995-3579 Toll Free US & Canada  
(817) 607-5100 Local & International

COMPLETE THE FOLLOWING ITEMS ON THIS FORM:

### PICK UP INFORMATION

Requested Pick Up Date: \_\_\_\_\_

SHIPPER NAME \_\_\_\_\_

SHIPPER ADDRESS \_\_\_\_\_

\_\_\_\_\_  
\_\_\_\_\_  
\_\_\_\_\_  
(City) (State) (Zip)

### DESTINATION

- I will be shipping to the **WAREHOUSE**

**FREEMAN / Exhibiting Company Name / Booth #**  
**IBTTA 85th ANNUAL MEETING**  
 C/O: FREEMAN  
 841 JOSEPH E LOWERY BLVD N W  
 ATLANTA, GA 30318  
 MUST BE DELIVERED BY SEPTEMBER 01, 2017

- I will be shipping to **SHOW SITE**

**FREEMAN / Exhibiting Company Name / Booth #**  
**IBTTA 85th ANNUAL MEETING**  
 C/O: FREEMAN  
 ATLANTA MARRIOTT MARQUIS  
 265 PEACHTREE CENTER AVE NE  
 ATLANTA, GA 30303  
 CANNOT BE DELIVERED BEFORE SEPTEMBER 10, 2017

### TYPE OF SERVICE

- Next Day Air: Delivery next business day by 5:00 PM
- Second Day Air: Delivery second business day by 5:00 PM
- 3-5 Day Service: Delivery within 3 - 5 business days
- Declared Value \$ \_\_\_\_\_

**Air Transportation charges are billed by Dimensional or Actual Weight, whichever is greater.**

- Standard Ground: Dependent on distance
- Expedited Ground: Tailored to specific requirements
- Specialized: Pad wrapped, uncrated, truck load

### SHIPPING INFORMATION

#### Items to be shipped

Number of Pieces	Est. Weight
___ Crates (wooden)	_____
___ Cartons (cardboard)	_____
___ Cases/Trunks (fiber) (color _____)	_____
___ Skids/Pallets	_____
___ Carpet (color _____)	_____
___ Other ( _____ )	_____
___ Total	_____

Size of largest piece: (H) \_\_\_\_\_ (W) \_\_\_\_\_ (L) \_\_\_\_\_

**NOTE: Shipments will be weighed and measured prior to delivery.**

### OUTBOUND SHIPPING

- I would like to schedule outbound Freeman Exhibit Transportation. Please provide me with a Material Handling Agreement at show site for my shipping instructions and signature. So we may print your Outbound Material Handling Agreement and labels, please complete the following information **if different from pick up address:**

Ship to address:

\_\_\_\_\_  
\_\_\_\_\_  
\_\_\_\_\_  
\_\_\_\_\_

Number of Labels : \_\_\_\_\_

FAX THIS COMPLETED FORM VIA:

E-mail:

[exhibit.transportation@freeman.com](mailto:exhibit.transportation@freeman.com)

or

Fax: (469) 621-5810

A TRANSPORTATION SPECIALIST  
WILL CALL YOU TO CONFIRM  
RECEIPT OF ORDER AND  
FINALIZE DETAILS.

SHOW # (435539) \_\_\_\_\_

FREEMAN exhibit transportation

# WHAT ARE FREIGHT SERVICES?

As the official service contractor, Freeman is the exclusive provider of freight services. Material handling includes unloading your exhibit material, storing up to 30 days in advance at the warehouse address, delivering to the booth, the handling of empty containers to and from storage, and removing of material from the booth for reloading onto outbound carriers. It should not be confused with the cost to transport your exhibit material to and from the convention or event. You have two options for shipping your advance freight — either to the warehouse or directly to show site.

## HOW DO I SHIP TO THE WAREHOUSE?

- We will accept freight beginning 30 days prior to show move-in.
- To check on your freight arrival, call Exhibitor Services at the location listed on the Quick Facts.
- To ensure timely arrival of your materials at show site, freight should arrive by the deadline date listed on the Quick Facts. Your freight will still be received after the deadline date, but additional charges will be incurred.
- The warehouse will receive shipments Monday through Friday, except holidays. Refer to the Quick Facts for warehouse hours. No appointment is necessary.
- The warehouse will accept crates, cartons, skids, trunks/cases and carpets/pads. Loose or pad-wrapped material must be sent directly to show site.
- All shipments must have a bill of lading or delivery slip indicating the number of pieces, type of merchandise and weight.
- Shipments received without receipts or freight bills, such as Federal Express and UPS, will be delivered to the booth without guarantee of piece count or condition.
- Certified weight tickets must accompany all shipments.
- Warehouse freight will be delivered to the booth prior to exhibitor set up.

## HOW DO I SHIP TO SHOW SITE?

- Freight will be accepted only during exhibitor move-in. Please refer to the Quick Facts for the specific exhibitor move-in dates and times.
- All shipments must have a bill of lading or delivery slip indicating the number of pieces, type of merchandise and weight.
- Shipments received without receipts or freight bills, such as Federal Express and UPS, will be delivered to the booth without guarantee of piece count or condition.
- Certified weight tickets must accompany all shipments.

## WHAT ABOUT PREPAID OR COLLECT SHIPPING CHARGES?

- Collect shipments will be returned to the delivery carrier.
- To ensure that your freight does not arrive collect, mark your bill of lading “prepaid.”
- “Prepaid” designates that the transportation charges will be paid by the exhibitor or a third party.

## HOW SHOULD I LABEL MY FREIGHT?

- The label should contain the exhibiting company name, the booth number and the name of the event.
- The specific shipping address for either the warehouse or show site is located on the Quick Facts.

## HOW DO I ESTIMATE MY MATERIAL HANDLING CHARGES?

- Charges will be based on the weight of your shipment. Each shipment received is billed individually and is subject to the applicable show weight minimum. The shipment weight will be rounded to the next 100 pounds. Each 100 pounds is considered one “cwt.” (one hundred weight). All shipments are subject to reweigh.
- On the Material Handling Order Form, select whether the freight will arrive at the warehouse or be sent directly to show site.
- Next, select the rate for the freight category that best describes your shipment. There are four categories of freight:

**Crated:** material that is skidded or is in any type of shipping container that can be unloaded at the dock with no additional handling required.

**Special Handling:** material delivered by the carrier in such a manner that it requires additional handling, such as ground unloading, stacked and constricted space unloading, designated piece unloading, loads mixed with pad-wrapped material, loads failing to maintain shipping integrity, and shipments that require additional time, equipment or labor to unload. Federal Express and UPS are included in this category due to their delivery procedures.



**Uncrated:** material that is shipped loose or pad-wrapped, and/or unskidded machinery without proper lifting points.

**Carpet and/or Pad Only:** shipments that consist of loose carpet and/or padding only require additional labor and equipment to unload.

- All inbound and outbound shipments are subject to overtime charges if the shipments are received, loaded or unloaded during the overtime hours specified on the Material Handling Order Form. This includes both warehouse and show site shipments.
- Add any late delivery or off-target charges listed on the Material Handling Order Form if the freight will be received after the deadlines listed on the Quick Facts.
- The above services, whether used completely or in part, are offered as a package and the charges will be based on the total inbound weight of the shipment.

## WHAT HAPPENS TO MY EMPTY CONTAINERS DURING THE SHOW?

- Pick up “Empty Labels” at the Freeman Service Center. Once the container is completely empty, place a label on each container individually. Labeled empty containers will be picked up periodically and stored in non-accessible storage during the event.
- At the close of the show, the empty containers will be returned to the booth in random order. Depending on the size of the show, this process may take several hours.

## HOW DO I PROTECT MY MATERIALS AFTER THEY ARE DELIVERED TO THE SHOW OR BEFORE THEY ARE PICKED UP AFTER THE SHOW?

- Consistent with trade show industry practices, there may be a lapse of time between the delivery of your shipment(s) to your booth and your arrival. The same is true for the outbound phase of the show — the time between your departure and the actual pick-up of your materials. During these times, your materials will be left unattended. We recommend that you arrange for a representative to stay with your materials or that you hire security services to safeguard your materials.

## HOW DO I SHIP MY MATERIALS AFTER THE CLOSE OF THE SHOW?

- Each shipment must have a completed Material Handling Agreement in order to ship materials from the show. All pieces must be labeled individually.
- To save time, complete and submit the Outbound Shipping Form in advance, or you may contact the Freeman Service Center at show site for your shipping documents.
- Once we receive your outbound shipping information we will create your Material Handling Agreement and shipping labels. If the shipping information is provided in advance, the Material Handling Agreement will be delivered to your booth with your invoice. Otherwise the Material Handling Agreement and labels will be available for pick up at the Freeman Service Center.

- After materials are packed, labeled, and ready to be shipped, the completed Material Handling Agreement must be turned in at the Freeman Service Center.
- Call your designated carrier with pick-up information. Please refer to the Quick Facts for specific dates, times and address for pick up. In the event your selected carrier fails to show by the final move-out day, your shipment will either be rerouted on Freeman’s carrier choice or delivered back to the warehouse at the exhibitor’s expense.
- For your convenience, approved show carriers will be on site to book outbound transportation if you have not made arrangements in advance.

## WHERE DO I GET A FORKLIFT?

- Forklift orders to install or dismantle your booth after materials are delivered may be ordered in advance or at show site. We recommend that you order in advance to avoid additional charges at show site. Refer to the Rigging Order Form for available equipment.
- Advance and show site orders for equipment and labor will be dispatched once a company representative signs the labor order at the Freeman Service Center.
- Start time is guaranteed only when equipment is requested for the start of the working day.

## DO I NEED INSURANCE?

- Be sure your materials are insured from the time they leave your firm until they are returned after the show. It is suggested that exhibitors arrange all-risk coverage. This can be done by riders to your existing policies.
- All materials handled by Freeman are subject to the Terms and Conditions, which can be found in the exhibit service manual or online at [www.freeman.com](http://www.freeman.com).

## OTHER AVAILABLE FREIGHT SERVICES

(may not be available in all locations)

- Cranes
- Accessible storage at show site
- Exhibit transportation services (see enclosed brochure)
- Security storage at show site
- Short-term and long-term warehouse storage
- Local pick-up and delivery
- Priority empty return

# FREEMAN

841 Joseph E. Lowery Blvd N W  
 Atlanta, GA 30318  
 (404) 253-6494 Fax: (469) 621-5610  
 FreemanAtlantaES@freeman.com

**INCLUDE THE FREEMAN METHOD OF PAYMENT FORM WITH YOUR ORDER**

NAME OF SHOW: IBTTA 85th ANNUAL MEETING / SEPTEMBER 10 - 13, 2017

COMPANY NAME \_\_\_\_\_ BOOTH #: \_\_\_\_\_

CONTACT NAME: \_\_\_\_\_ PHONE #: \_\_\_\_\_

E-MAIL ADDRESS \_\_\_\_\_

For Assistance, please call 404-253-6494 to speak with one of our experts.

**Let Freeman OnLine® estimate your material handling charges for you.** Log on to [www.freeman.com/store](http://www.freeman.com/store), select your show and click on "Estimate My Material Handling Costs". From Freeman OnLine® you can print extra shipping labels, get tips on how to package your freight and much more.

## MATERIAL HANDLING SERVICES

- CRATED:** Material that is skidded or is in any type of shipping container that can be unloaded at the dock with no additional handling required.
- SPECIAL HANDLING:** (See definitions on back) Material delivered in such a manner that it requires additional handling, such as ground unloading, stacked or constricted space unloading, designated piece unloading, shipment integrity, alternate delivery location, loads mixed with pad wrapped material, no documentation and shipments that require additional time, equipment or labor to unload. **Federal Express, UPS & DHL** are included in this category due to their delivery procedures.
- UNCRATED:** Material that is shipped loose or pad-wrapped, and/or unskidded machinery without proper lifting points.
- CARPET AND/OR PAD ONLY:** Shipments that consist of loose carpet and/or padding only require additional labor and equipment to unload.
- STRAIGHT TIME:** 8:00 A.M. to 5:00 P.M. Monday through Friday
- OVERTIME:** 5:00 P.M. to 8:00 A.M. Monday through Friday, all day Saturday, Sunday, and Holidays  
 (Overtime will be applied to all freight received at the warehouse and/or show site that must be moved into or out of booth during above listed times.)

Description	Price Per CWT	200 lb. Minimum
<b>RATE CLASSIFICATIONS:</b>		
<b>Warehouse Shipment (200 lb. minimum)</b>		
Crated or Skidded Shipment.....	\$ 82.50	165.00
Special Handling Shipment.....	\$107.25	214.50
Carpet and/or Pad Only Shipment.....	\$123.75	247.50
<b>Show Site Shipment (200 lb. minimum)</b>		
Crated or Skidded Shipment.....	\$ 84.25	168.50
Special Handling Shipment.....	\$109.75	219.50
Uncrated or Pad Wrapped Shipment.....	\$126.50	253.00
Carpet and/or Pad Only Shipment.....	\$126.50	253.00
<b>Small Package - Maximum weight is 30 lbs per shipment*</b>		
Per Shipment.....	\$ 40.00	

\*A small package shipment is a shipment totaling any number of pieces with a combined weight not to exceed 30 lbs that is received on the same day, from the same shipper and delivered by the same carrier.

**ADDITIONAL SURCHARGES:**

<b>Shipment Delivered after Deadline Date (in addition to above rates)</b>		
Warehouse Shipment after Deadline .....	\$ 20.75	41.50
Show Site Shipment after Deadline .....	\$ 21.25	42.50
<b>Overtime Charge - Inbound (in addition to above rates)</b>		
Crated or Skidded Shipment.....	\$ 21.25	42.50
Special Handling Shipment.....	\$ 27.50	55.00
Uncrated or Pad Wrapped Shipment.....	\$ 31.75	63.50
Carpet and/or Pad Only Shipment.....	\$ 31.75	63.50
<b>Overtime Charge - Outbound (in addition to above rates)</b>		
Crated or skidded Shipment .....	\$ 21.25	42.50
Special Handling Shipment.....	\$ 27.50	55.00
Uncrated or Pad Wrapped Shipment.....	\$ 31.75	63.50
Carpet and/or Pad Only Shipment.....	\$ 31.75	63.50

Description	Weight	CWT	Price per CWT	Estimated Total Cost (200 lb. Min.)
	÷ 100 =			
<b>Surcharges</b>	÷ 100 =			
			<b>0.00% Tax</b>	<b>N/A</b>
			<b>Total</b>	

**FREEMAN material handling**

# SPECIAL HANDLING DEFINITIONS

for frequently asked questions and material handling estimator tools, go to [www.freeman.com/store](http://www.freeman.com/store)

Special handling applies to shipments that are loaded by cubic space and/or packed in such a manner as to require additional labor/handling, such as ground unloading, constricted space unloading, designated piece unloading, or stacked shipments. Also included are shipment integrity, alternate delivery locations, mixed shipments, and shipments without individual bills of lading. Shipments loaded in this manner require additional time, labor, or equipment, to unload, sort and deliver.

## **What is Ground Loading/Unloading?**

Vehicles that are not dock height, preventing the use of loading docks, such as U-hauls, flat bed trailers, double drop trailers, company vehicles with trailers that are not dock level, etc.

## **What is Constricted Space Loading/Unloading?**

Trailer loaded "high and tight" shipments that are not easily accessible. Freight is loaded to full capacity of trailer – top to bottom, side to side. One example of this is freight that is loaded down one side of a trailer that must be bypassed to reach targeted freight.

## **What is Designated Piece Loading/Unloading?**

Drivers that require the loading crew to bring multiple pieces of the freight to the rear of the trailer to select the next piece, having to remove freight from the trailer then reload to fit or the trailer must be loaded in a sequence to ensure all items fit.

## **What are Stacked Shipments?**

Shipments loaded in such a manner requiring multiple items to be removed to ground level for delivery to booth. Stacked or "cubed out" shipments, loose items placed on top of crates and/or pallets constitute special handling.

## **What is Shipment Integrity?**

Shipment integrity involves shipments on a carrier that are intermingled, or delivered in such a manner that additional labor is needed to sort through and separate the various shipments on a truck for delivery to our customers.

## **What is Alternate Delivery Location?**

Alternative delivery location refers to shipments that are delivered by a carrier that requires us to deliver some shipments to different levels in the same building, or to other buildings in the same facility.

## **What are Mixed Shipments?**

Mixed shipments are defined as shipments of mixed crated and uncrated goods, where the percentage of uncrated is minimal and does not warrant the full uncrated rate for the shipment, but does require special handling. Freeman defines special handling for mixed loads as having less than 50% of the volume as uncrated.

## **What does it mean if I have "No Documentation"?**

Shipments arrive from a small package carrier (including, among others, Federal Express, UPS & DHL) without an individual Bill of Lading, requiring additional time, labor and equipment to process.

## **What is the difference between Crated and Uncrated Shipments?**

Crated shipments are those that are packed in any type of shipping container that can be unloaded at the dock with no additional handling required. Such containers include crates, fiber cases, cartons, and properly packed skids. An uncrated shipment is material that is shipped loose or pad-wrapped, and/or unskidded without proper lifting points.

## **What about carpet only shipments?**

Shipments that consist of loose carpet and/or padding only require additional labor and equipment to unload.

# FREEMAN

841 Joseph E Lowery Blvd N W  
 Atlanta, GA 30318  
 (404) 253-6494 Fax: (469) 621-5610  
 FreemanAtlantaES@freeman.com

OUTBOUND MATERIAL HANDLING  
 AND SHIPPING LABELS

NAME OF SHOW: **IBTTA 85th ANNUAL MEETING / SEPTEMBER 10 - 13, 2017**

COMPANY NAME: \_\_\_\_\_ BOOTH #: \_\_\_\_\_ BOOTH SIZE: \_\_\_\_\_ X \_\_\_\_\_

CONTACT NAME : \_\_\_\_\_ PHONE #: \_\_\_\_\_

E-MAIL ADDRESS : \_\_\_\_\_

For Assistance, please call (404) 253-6494 to speak with one of our experts.

For fast, easy ordering, go to [www.freeman.com](http://www.freeman.com)

**EVERY OUTBOUND SHIPMENT WILL REQUIRE A MATERIAL HANDLING AGREEMENT AND SHIPPING LABELS. WE WOULD BE HAPPY TO PREPARE THESE FOR YOU AND DELIVER THEM TO YOUR BOOTH PRIOR TO SHOW CLOSE. TO TAKE ADVANTAGE OF THIS SERVICE, PLEASE COMPLETE AND RETURN THIS FORM.**

**SHIPPING INFORMATION**

**SHIP TO:** COMPANY NAME: \_\_\_\_\_

DELIVERY ADDRESS: \_\_\_\_\_

\_\_\_\_\_

CITY: \_\_\_\_\_ STATE/ PROVINCE: \_\_\_\_\_ ZIP/ POSTAL CODE: \_\_\_\_\_

PHONE#: \_\_\_\_\_ ATTN: \_\_\_\_\_

SPECIAL INSTRUCTIONS: \_\_\_\_\_

**BILL TO:**  Same as Ship to:

COMPANY NAME: \_\_\_\_\_

DELIVERY ADDRESS: \_\_\_\_\_

\_\_\_\_\_

CITY: \_\_\_\_\_ STATE/ PROVINCE: \_\_\_\_\_ ZIP/ POSTAL CODE: \_\_\_\_\_

**METHOD OF SHIPMENT**

**Select a Carrier:**

**Freeman Exhibit Transportation**       **Other Carrier**

No need to schedule your outbound shipment.      Carrier Name: \_\_\_\_\_  
 Charges will appear on your Freeman invoice.      Carrier Phone: \_\_\_\_\_

Freeman will make arrangements for all Freeman Exhibit Transportation shipments.  
 Arrangements for pick-up by other carriers is the responsibility of the exhibitor.

**Select a Level of Service:**

1 Day: Delivery next business day       Standard Ground  
 2 Day: Delivery by 5:00 P.M. second business day       Specialized: Pad wrapped, uncrated, or truckload  
 Deferred: Delivery within 3-5 business days

**Select Shipment Options (if applicable)**

Have loading dock       Lift gate required  
 Inside delivery       Air ride required  
 Pad wrap required       Residential  
 Do not stack

**Select Desired Number of Labels:** \_\_\_\_\_

Once your shipment is packed and ready to be picked up, please return the Material Handling Agreement to the Exhibitor Services Center. Shipments without a Material Handling Agreement turned in will be returned to our warehouse at exhibitor's expense.

**F R E E M A N**

**R U S H**

**DO NOT DELAY**

**F R E E M A N**

**R U S H**

**DO NOT DELAY**

**RECEIVING DATE BEGINS: AUGUST 11, 2017**

**RECEIVING DATE BEGINS: AUGUST 11, 2017**

**DEADLINE DATE IS: SEPTEMBER 01, 2017**

**DEADLINE DATE IS: SEPTEMBER 01, 2017**

**TO:** \_\_\_\_\_  
*EXHIBITOR NAME*

**TO:** \_\_\_\_\_  
*EXHIBITOR NAME*

**C/O: FREEMAN**  
841 JOSEPH E LOWERY BLVD N W  
  
ATLANTA, GA 30318

**C/O: FREEMAN**  
841 JOSEPH E LOWERY BLVD N W  
  
ATLANTA, GA 30318

**WAREHOUSE**

**WAREHOUSE**

**EVENT:** IBTTA 85th ANNUAL MEETING

**EVENT:** IBTTA 85th ANNUAL MEETING

**BOOTH NO:** \_\_\_\_\_ **NO.** \_\_\_\_\_ **OF** \_\_\_\_\_ **PCS**

**BOOTH NO:** \_\_\_\_\_ **NO.** \_\_\_\_\_ **OF** \_\_\_\_\_ **PCS**

THE ABOVE LABELS ARE PROVIDED FOR YOUR CONVENIENCE.  
PLACE ONE ON EACH PIECE SHIPPED TO ENSURE PROPER DELIVERY.  
IF MORE LABELS ARE NEEDED, COPIES ARE ACCEPTABLE.

**F R E E M A N**

**F R E E M A N**

**R U S H**

**R U S H**

**DO NOT DELAY**

**DO NOT DELAY**

**CANNOT DELIVER BEFORE SEPTEMBER 10, 2017**

**CANNOT DELIVER BEFORE SEPTEMBER 10, 2017**

TO: \_\_\_\_\_  
*EXHIBITOR NAME*

TO: \_\_\_\_\_  
*EXHIBITOR NAME*

**C/O: FREEMAN**  
ATLANTA MARRIOTT MARQUIS  
265 PEACHTREE CENTER AVE NE  
  
ATLANTA, GA 30303

**C/O: FREEMAN**  
ATLANTA MARRIOTT MARQUIS  
265 PEACHTREE CENTER AVE NE  
  
ATLANTA, GA 30303

**SHOW SITE**

**SHOW SITE**

EVENT: IBTTA 85th ANNUAL MEETING

EVENT: IBTTA 85th ANNUAL MEETING

BOOTH NO: \_\_\_\_\_ NO. \_\_\_\_\_ OF \_\_\_\_\_ PCS

BOOTH NO: \_\_\_\_\_ NO. \_\_\_\_\_ OF \_\_\_\_\_ PCS

THE ABOVE LABELS ARE PROVIDED FOR YOUR CONVENIENCE.  
PLACE ONE ON EACH PIECE SHIPPED TO ENSURE PROPER DELIVERY.  
IF MORE LABELS ARE NEEDED, COPIES ARE ACCEPTABLE.

# FURNISH FORWARD

---

Freeman sets the stage for success with temporary furnishings that make lasting impressions. With high-quality furniture in shapes and styles that suit your budget and design needs, Freeman always provides an ideal solution for your exhibit.

- Sleek and professional furniture products transform your exhibit into a destination
- Extensive selection of seating, surfaces, and display fixtures provides a completely custom and comprehensive approach to your brand experience
- No assembly required: Hassle-free shipment, setup, and tear down allow your exhibitors to focus on what matters: new business
- Prices are all-inclusive and cover delivery, installation and material handling with no hidden fees



# SUPERIOR SEATING

---

**Sit back and relax** – your search for comfortable seating is over. Choose from a sleek selection of sofas, loveseats and chairs that are sure to take your exhibit design to the next level.

## ITEMS PICTURED BELOW

Swanson Chair | 810875 | **Page 10**

Silverado Cocktail Table | 82014 | **Page 17**

Powered Locking Pedestal, 42" | 85063 | **Page 23**





## SEATING

### Naples



**CHAIR** *SELECT*  
black leather **810119**

36"L 30"D 28"H  
⊕ Powered options available



**LOVESEAT** *SELECT*  
black leather **830120**

62"L 30"D 28"H  
⊕ Powered options available



**SOFA** *SELECT*  
black leather **830119**

87"L 30"D 28"H  
⊕ Powered options available

### Heathrow



**ARMLESS CHAIR** *SELECT*  
black leather **810116**

24"L 24"D 28"H



**CORNER CHAIR** *SELECT*  
black leather **810117**

24"L 24"D 28"H



**SOFA** *SELECT*  
black leather **830116**

48"L 24"D 28"H

possible configurations

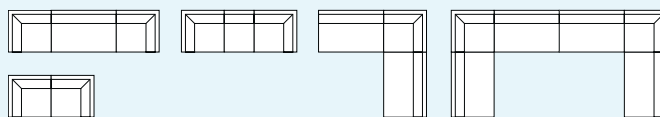

⊕ See pages 22 and 23 for all Powered options.

## SEATING

### South Beach



**SOFA** *SELECT*  
platinum suede **8301**

69"L 29"D 33"H



**OTTOMAN** *SELECT*  
platinum suede **8151**

25"L 31"D 18"H

possible configurations

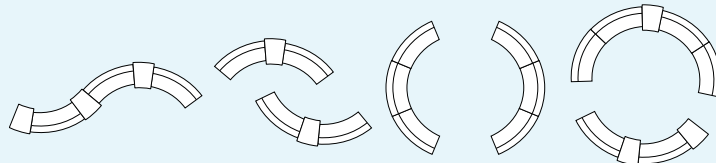

### Key Largo



**LOVESEAT** *SELECT*  
black fabric **830950**

57"L 35"D 34"H



**SOFA** *SELECT*  
black fabric **830951**

79"L 35"D 34"H



**CHAIR** *SELECT*  
black fabric **810950**

35"L 35"D 34"H

## SEATING

### Allegro

**CHAIR** **SELECT**

blue fabric **81019**

36"L 34.5"D 30"H



**SOFA** **SELECT**

blue fabric **83015**

73"L 34.5"D 30"H



### Fairfax

**CHAIR** **SELECT**

white vinyl/brushed metal **810949**

27"L 26"D 30"H



**SOFA** **SELECT**

white vinyl/brushed metal **830949**

62"L 26"D 30"H



### Hopi

**CHAIR** **SELECT**

gray linen **810140**

21"L 25"D 34"H



**LOVESEAT** **SELECT**

gray linen **830150**

48"L 25"D 34"H



### Tangiers

**CHAIR** **SELECT**

beige fabric **810118**

34"L 37"D 36"H



**SOFA** **SELECT**

beige fabric **830118**

78"L 37"D 36"H



### Roma

**CHAIR** **SELECT**

white vinyl **81020**

37"L 31"D 33"H

⊕ Powered options available



**SOFA** **SELECT**

white vinyl **83016**

78"L 31"D 33"H

⊕ Powered options available



⊕ See pages 22 and 23 for all Powered options.

# CASUAL SEATING

Look no further for a great variety of **informal, modern seating options**. Here you will find chairs, sofas, stools, ottomans – even sophisticated bar sets – that turn exhibits into destinations.

## OTTOMANS

**ENDLESS SQUARE** *SELECT*

*white leather* 815122  
*black leather* 815123

34"L 34"D 15"H

**ENDLESS CURVED OTTOMAN** *SELECT*

*white leather* 815953  
*black leather* 815952

60.5"L 37.5"D 15"H



**OTTOMAN BENCH** *SELECT*

*white leather* 815120  
*black leather* 815121

60"L 20"D 18"H

**HALF BENCH OTTOMAN** *SELECT*

*white vinyl* 815119

39"L 22.5"D 18"H



### ITEMS PICTURED BELOW

Roma Sofa Powered | 83017 | **Page 5, 22**

Regis Bench/Table | 82074 | **Page 18**

Swanson Chair | 810875 | **Page 10**

Work Desk | 820706 | **Page 21**

Regis End Table | 82075 | **Page 18**

Ice Side Chair | 810814 | **Page 9**



OTTOMANS

VIBE CUBE **SELECT**

- blue vinyl 81518
- red vinyl 81519
- orange vinyl 81525
- pink vinyl 81520
- yellow vinyl 81517
- black vinyl 81530
- white vinyl 81531

18"L | 18"D | 18"H



MARCHE SWIVEL OTTOMAN **SELECT**

- gray fabric 815151
- red fabric 815154
- blue fabric 815159
- linen fabric 815152
- meadow green fabric 815157
- pear yellow fabric 815158
- plum fabric 815156
- raspberry fabric 815153
- rose quartz fabric 815155
- white vinyl 815150

17"Round | 18"H



EDGE LED CUBE OTTOMAN\* **SELECT**

- high density plastic 81526

20"L | 20"D | 20"H



SEATING

BANQUETTES

CENTER CONE **SELECT**  
8506

38"Round | 51"H

Powered

Banquette Cone has 3 AC and 2 USB plugs built into the center cone.

possible configurations

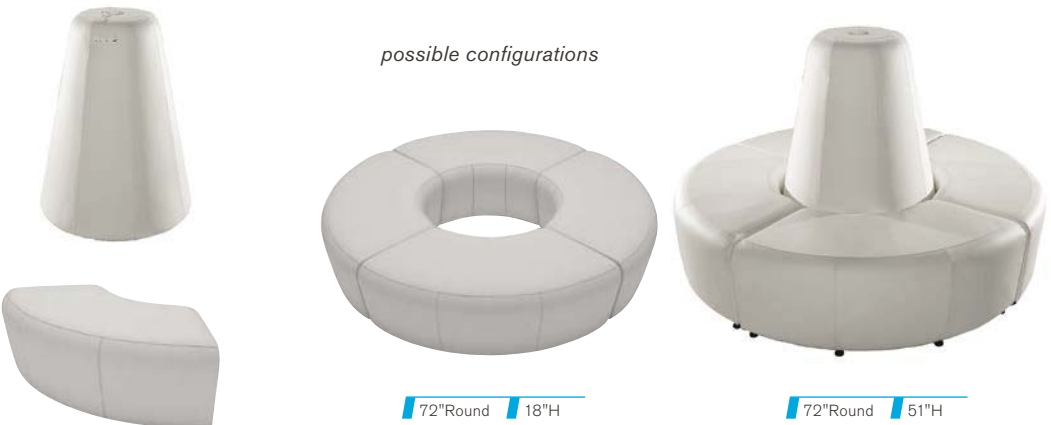

QUARTER CURVED OTTOMAN **SELECT**  
8507

53"L | 22"D | 18"H

See pages 22 and 23 for all Powered options.

\*Electrical power must be ordered separately

## OCCASIONAL CHAIRS

**BLACK DIAMOND  
SIDE CHAIR** **ESSENTIALS**  
71089

21"W | 23"L | 32"H

**BLACK DIAMOND  
ARMCHAIR** **ESSENTIALS**  
71090

20"W | 21"L | 33"H

**DIVA CHAIR** **ESSENTIALS**  
71091

18"W | 16"L | 31"H



**LIMERICK® CHAIR  
BY HERMAN MILLER** **ESSENTIALS**  
gray 210108

18"W | 17.75"L | 33"H

**MADRID CHAIR** **SELECT**  
black leather/chrome 8102  
white leather/chrome 810816

30"L | 30"D | 31"H



### ITEMS PICTURED BELOW

Powered Locking Pedestal, 36" | 85061 | **Page 23**

White Vibe Cube | 81531 | **Page 7**



OCCASIONAL CHAIRS

**MEETING CHAIR** *SELECT*  
 white vinyl **810948**  
 espresso bonded leather **810835**  
 taupe microfiber **810836**

25.5"L 23.5"D 34"H



**TUB CHAIR** *SELECT*  
 black fabric **8103**

31"L 31"D 31"H

**MADDEN CHAIR** *SELECT*  
 light gray vinyl **810843**

27"L 32"D 33"H



**ICE SIDE CHAIR** *SELECT*  
 transparent **810814**

17.25"L 20"D 32"H

**MALBA CHAIR** *SELECT*  
 gray **810131**  
 green **810130**

20"L 20"D 32"H



## OCCASIONAL CHAIRS

### CHRISTOPHER CHAIR **SELECT**

white vinyl/chrome **810846**

17"L 19"D 35"H

### ZENITH CHAIR **SELECT**

white/chrome **810851**

18.5"L 22"D 32"H

### RUSTIQUE CHAIR WITH ARMS **SELECT**

gunmetal **810841**

20"L 18"D 31"H



### RAZOR ARMLESS CHAIR **SELECT**

white high density plastic **810837**

15.38"L 15.5"D 30.5"H

### SWANSON CHAIR **SELECT**

white vinyl **810875**

28"L 25"D 30"H



### BERLIN STACK CHAIR **SELECT**

white & red plastic/chrome **810811**  
white & black plastic/chrome **810810**

18"L 22"D 32"H

### WENDY CHAIR **SELECT**

clear acrylic **810847**

15"L 20"D 36"H





## CONFERENCE CHAIRS

### GRAY GASLIFT CHAIR **ESSENTIALS**

with arms **71046**  
without arms **71045**

26"W 20"L 38"H Adjustable

### LABREA CHAIR **SELECT**

charcoal gray fabric **810874**

35"L 27"D 40"H

### ALTURA CONFERENCE/ GUEST CHAIR **SELECT**

black fabric/black steel **81063**

25"L 20"D 34"H



### LUXOR EXECUTIVE CHAIR **SELECT**

black leather **810807**

27"L 28"D 47"H Adjustable

### PRO EXECUTIVE HIGH BACK CHAIR **SELECT**

white vinyl **810844**

black vinyl **810946**

25"L 24"D 48"H Adjustable



### PRO EXECUTIVE MID BACK CHAIR **SELECT**

white vinyl **810945**

black vinyl **810944**

24"L 22"D 40"H Adjustable

### PRO EXECUTIVE GUEST CHAIR **SELECT**

black vinyl **810947**

24"L 22"D 36"H



# FREEMAN

## BARS & BARSTOOLS

**MARTINI BAR** **SELECT**  
 gray metal rounded bar with frosted  
 glass top and chrome legs **8501**

67"L | 22"D | 45"H

possible configurations

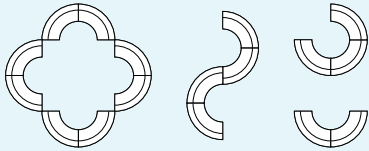

**BLACK DIAMOND STOOL** **ESSENTIALS**  
**71088**

22"W | 18"L | 46"H

**GRAY GASLIFT STOOL** **ESSENTIALS**  
 with arms **71048**  
 without arms **71047**

24"W | 20"L | 46"H | Adjustable

**DIVA COUNTER STOOL** **ESSENTIALS**  
**71092**

17"W | 16"L | 36"H

The Intermediate 25" seating height



**LIMERICK® STOOL**  
**BY HERMAN MILLER** **ESSENTIALS**  
 gray **210109**

18"W | 17.75"L | 44"H

**LIFT HYDRAULIC**  
**BARSTOOL** **SELECT**  
 gray vinyl/chrome **810872**  
 red vinyl/chrome **810873**  
 black vinyl/chrome **810871**  
 white vinyl/chrome **810870**

15" Round | 23-33.5"H | Adjustable



**APEX BARSTOOL** **SELECT**  
 black vinyl **33010**  
 blue ultra suede **33009**  
 red vinyl **33042**  
 white vinyl **33043**

21"L | 21"D | 33"H



BARS & BARSTOOLS

**BANANA BARSTOOL** **SELECT**

white vinyl/chrome **810103**  
black vinyl/chrome **810104**

21"L 22"D 30"H

**ZENITH BARSTOOL** **SELECT**

white/chrome **810850**

19"L 20"D 44"H

**ZOEY BARSTOOL** **SELECT**

white vinyl/chrome **810840**  
black vinyl/chrome **810834**

15"L 16"D 26-30.5"H



**CHRISTOPHER BARSTOOL** **SELECT**

white **810848**

19"L 15"D 41"H

**ICE BARSTOOL** **SELECT**

transparent/chrome legs **810815**

16"L 14"D 33"H

**SHARK SWIVEL BARSTOOL** **SELECT**

white plastic/chrome **810202**

22"L 19"D 34-44"H Adjustable



**RUSTIQUE BARSTOOL** **SELECT**

gunmetal **810839**

13"L 13"D 30"H

**GIN BARSTOOL** **SELECT**

maple wood/chrome **810505**

16"L 16"D 29"H

**OSLO BARSTOOL** **SELECT**

blue plastic/chrome **810200**  
white plastic/chrome **810201**

17"L 20"D 30"H



# TURN THE TABLES IN YOUR FAVOR

---

Bring professionalism to the table with our sleek variety of surfaces and tabletops. Choose from modern glass tops and more.

## ITEMS PICTURED BELOW

Endless Square Ottoman | 815122 | **Page 6**

Geo End Table | 82035 | **Page 17**

30" Round Hydraulic Base Bar Table | 820230 | **Page 16**

Ice Barstool | 810815 | **Page 13**



## DRAPED OR UNDRAPED TABLES & COUNTERS



### ESSENTIALS

TABLES (30" HEIGHT)	3'	4'	6'	8'
Draped	130330	130430	130630	130830
Draped on Fourth Side			12404630	12404830
Undraped	131330	131430	131630	131830

COUNTERS (42" HEIGHT)	3'	4'	6'	8'
Draped	130342	130442	130642	130842
Draped on Fourth Side			12404642	12404842
Undraped	131342	131442	131642	131842

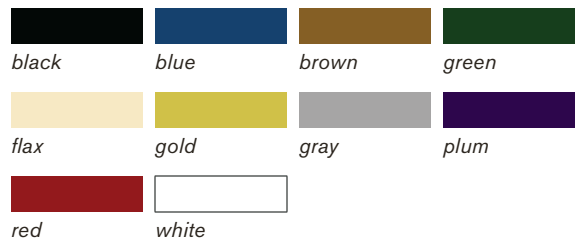

Table-top risers are also available in a variety of sizes. See order form for details.



PEDESTAL TABLES

Soho Series



**BLACK-TOP CAFÉ** **ESSENTIALS**  
72069

24" Round 30"H

72067

36" Round 30"H

**BLACK-TOP MINI** **ESSENTIALS**  
72066

18" Round 18"H



**BLACK-TOP BISTRO** **ESSENTIALS**  
72070

24" Round 42"H

72068

36" Round 42"H

Chelsea Series



**BUTCHER BLOCK-TOP CAFÉ** **ESSENTIALS**  
72063

30" Round 30"H

72064

36" Round 30"H



**BUTCHER BLOCK-TOP BISTRO** **ESSENTIALS**  
720163

30" Round 42"H

720164

36" Round 42"H

**STANDARD BASE CAFÉ TABLE** **SELECT**

liquid white 820232

blue steel 8201203

30" Round 29"H

**STANDARD BASE BAR TABLE** **SELECT**

liquid white 820231

blue steel 8201204

30" Round 42"H



**HYDRAULIC BASE CAFÉ TABLE** **SELECT**

liquid white 820224

30" Round 29"H



**MADISON HYDRAULIC BASE CAFÉ TABLE** **SELECT**

gray acajou 820241

30" Round 29"H



**MADISON CAFÉ TABLE** **SELECT**

gray acajou 820265

30" Round 29"H

**HYDRAULIC BASE BAR TABLE** **SELECT**

liquid white 820230

30" Round 45"H

**MADISON HYDRAULIC BASE BAR TABLE** **SELECT**

gray acajou 820240

30" Round 45"H

**MADISON BAR TABLE** **SELECT**

gray acajou 820264

30" Round 42"H

OCCASIONAL, END & COCKTAIL TABLES

Studio Series

BLACK END TABLE **ESSENTIALS** 115104

17"W 17"L 18"H

BLACK COCKTAIL TABLE **ESSENTIALS** 115103

36"W 20"L 15"H



Silverado

END TABLE **SELECT** tempered glass/painted steel 82015

24" Round 22"H

TABLE **SELECT** tempered glass/painted steel 82014

36" Round 17"H



Alondra

END TABLE **SELECT** glass/chrome 820252

20"L 20"D 20"H

COCKTAIL TABLE **SELECT** glass/chrome 820250

47"L 24"D 16"H

END TABLE **SELECT** wood/chrome 820253

20"L 20"D 21"H

COCKTAIL TABLE **SELECT** wood/chrome 820251

47"L 24"D 17"H



Geo

END TABLE **SELECT** wood/black steel 82028

20"L 20"D 21"H

COCKTAIL TABLE **SELECT** wood/black steel 82027

47"L 24"D 17"H

END TABLE **SELECT** glass/chrome 82035

26"L 26"D 20"H

TABLE **SELECT** glass/chrome 82034

50"L 22"D 16"H



# FREEMAN

## OCCASIONAL, END & COCKTAIL TABLES

### Sydney

**END TABLE** **SELECT**

black laminate/brushed steel **82054**  
white laminate/brushed steel **82055**

27"L 23"D 22"H

**TABLE** **SELECT**

black laminate/brushed steel **82052**  
white laminate/brushed steel **82053**

48"L 26"D 18"H

⚡ Powered options available



### Oliver

**END TABLE** **SELECT**

walnut finish **82088**

22" Round 22"H

**TABLE** **SELECT**

walnut finish **82087**

47"L 27"D 19"H



### Regis

**END TABLE** **SELECT**

brushed metal **82075**

16"L 15.5"D 16.5"H

**BENCH/TABLE** **SELECT**

brushed metal **82074**

47"L 15.5"D 16"H



**AURA ROUND TABLE** **SELECT**

white metal **820844**

15" Round 22"H

**EDGE LED CUBE TABLE\*** **SELECT**

white plastic/clear  
acrylic top **82057**

20"L 20"D 20"H



⚡ See pages 22 and 23 for all Powered options.

\*Electrical power must be ordered separately



OCCASIONAL, END & COCKTAIL TABLES

GEO SQUARE-ROUND TABLE **SELECT**

glass/black steel **82043**  
 glass/chrome **82044**

42"L 42"D 29"H



CONFERENCE TABLES

GEO CONFERENCE TABLE **SELECT**

glass/black steel **82041**  
 glass/chrome **82051**

60"L 36"D 29"H

MADISON CONFERENCE TABLE **SELECT**

gray acajou **820260**

42"Round 29"H



TABLES

ITEMS PICTURED BELOW

Endless Curved Ottoman | 815953 | **Page 6**

Silverado Table | 82014 | **Page 17**

Zoey Barstools | 810840 | **Page 13**

30" Round Hydraulic Base Bar Table | 820230 | **Page 16**



# FREEMAN

## CONFERENCE TABLES



**MADISON 5' TABLE** **SELECT**  
gray acajou **820261**  
60"L 48"D 29"H



**MADISON 8' TABLE** **SELECT**  
gray acajou **820262**  
96"L 60"D 29"H



**MADISON 10' TABLE** **SELECT**  
gray acajou **820263**  
120"L 48"D 29"H



**COMMUNAL TABLE (MAPLE WITH GROMMETS)** **SELECT**  
laminate/metal  
**82058**  
72"L 26"D 30"H  
**82059**  
72"L 26"D 42"H



**COMMUNAL TABLE (MAPLE)** **SELECT**  
laminate/metal  
**82067**  
72"L 26"D 30"H  
**82068**  
72"L 26"D 42"H



**COMMUNAL TABLE (WHITE)** **SELECT**  
laminate/metal  
**82063**  
72"L 26"D 30"H  
**82066**  
72"L 26"D 42"H



**42" ROUND WHITE CONFERENCE TABLE** **SELECT**  
white laminate **820708**  
42" Round 29"H



**6' OVAL CONFERENCE TABLE** **SELECT**  
granite nebula **820203**  
72"L 42"D 29"H



**8' RECTANGULAR CONFERENCE TABLE** **SELECT**  
granite **820115**  
96"L 44"D 29"H

## OFFICE

**MADISON DESK** **SELECT**  
gray acajou **84075**

60"L 30"D 29"H

**MADISON CREDENZA** **SELECT**  
gray acajou **84077**

60"L 20"D 29"H

**MADISON BOOKCASE** **SELECT**  
gray acajou **84078**

36"L 12"D 72"H



## COMPUTER DESK / TABLE

**WORK DESK** **SELECT**  
white laminate **820706**

48"L 24"D 30"H

**MERLIN TABLE** **SELECT**  
gray laminate **820707**

46"L 29"D 30"H



TABLES

### ITEMS PICTURED BELOW

Key Largo Sofa | 830951 | **Page 4**

Black Diamond Stool | 71088 | **Page 12**

Key Largo Chair | 810950 | **Page 4**

Soho Black Top Bistro | 36" Round - 72068 | **Page 16**

Sydney Powered Table | 82052 | **Page 18, 23**

Aura Round Table | 820844 | **Page 19**



## POWERED

All Powered options will have an **adapter included with rental**. Additional adapters can be ordered separately.

### POWERED SEATING

#### NAPLES CHAIR, POWERED\* **SELECT**

black vinyl **810120**

36"L 30"D 28"H



Power Panel Detail



#### NAPLES LOVESEAT, POWERED\* **SELECT**

black vinyl **830122**

62"L 30"D 28"H



Power Panel Detail



#### NAPLES SOFA, POWERED\* **SELECT**

black vinyl **830121**

87"L 30"D 28"H



Power Panel Detail

#### ROMA CHAIR, POWERED\* **SELECT**

white vinyl **81021**

37"L 31"D 33"H



Power Panel Detail



#### ROMA SOFA, POWERED\* **SELECT**

white vinyl **83017**

78"L 31"D 33"H



Power Panel Detail

*\*Electrical power must be ordered separately*

POWERED TABLES

**G30 COCKTAIL TABLE, POWERED\*** **SELECT**  
white top **82070**

72"L 26"D 18"H

**G30 CAFÉ TABLE, POWERED\*** **SELECT**  
white top **82071**

72"L 26"D 30"H

**G30 BAR TABLE, POWERED\*** **SELECT**  
white top **82072**

72"L 26"D 42"H



**TECH DESK WITH 3 DRAWER FILE CABINET, POWERED\*** **SELECT**  
black metal **84083**  
desk only **84084**

60"L 30"D 30"H

**SYDNEY COCKTAIL TABLE, POWERED\*** **SELECT**  
black laminate/brushed steel **82076**  
white laminate/brushed steel **82073**

48"L 26"D 18"H



POWERED PRODUCT PEDESTALS

**POWERED\* LOCKING PEDESTAL, 36"** **SELECT**  
black **85060**  
white **85061**

24"L 24"D 36"H

**POWERED\* LOCKING PEDESTAL, 42"** **SELECT**  
black **85062**  
white **85063**

24"L 24"D 42"H



Power Panel Detail

ADAPTERS

**4-WAY CHARGING ADAPTER\*** **SELECT**  
black **850800**  
white **850801**

36"L

All Powered options will have one adapter included per power panel. Additional adapters can be ordered with the rental.



BANQUETTE

**CENTER CONE** **SELECT**  
**8506**

38"Round 51"H

Powered

Banquette Cone has 3 AC and 2 USB plugs built into the center cone.



\*Electrical power must be ordered separately

POWERED

STORAGE

**3 DRAWER  
FILE CABINET  
ON CASTORS** **SELECT**  
**84080**

16"L 20"D 28"H



**FILE CABINET  
WITH LOCK** **ESSENTIALS**  
*standard size*

**TWO-DRAWER**  
**74082**

15"W 29"L 28"H

**FOUR-DRAWER**  
**74081**

15"W 29"L 50"H



REFRIGERATOR



**SMALL  
REFRIGERATOR\*** **ESSENTIALS**  
**75057**

19"W 19"L 34"H



**REFRIGERATOR\*** **SELECT**  
*white - 14.0 cubic feet* **8503001**

28"L 28"D 64"H

LIGHTING



**MASON TABLE  
LAMP\*** **SELECT**  
*white/brushed silver* **850707**

16" Round 26"H



**MASON FLOOR  
LAMP\*** **SELECT**  
*white/brushed silver* **850708**

18" Round 55"H

*\*Electrical power must be ordered separately*

# DISPLAY

Some of the most essential elements of your exhibit are the surfaces on which you display your show materials. That's why we have an appealing variety of displays, from standing cylinders to sleek computer desks to draped tables and counters, to ensure your show space will be both attractive and interactive.

## DISPLAY CYLINDERS **ESSENTIALS**

black

low **75020**

30"W 15"H

medium **75021**

18"W 20"H

high **75022**

24"W 36"H

Available in rectangular sizes.



## DISPLAY CUBES **ESSENTIALS**

black

12" small **75030**

12"W 12"L 42"H

18" medium **75031**

18"W 18"L 36"H

24" large **75032**

24"W 24"L 42"H



## ORION COMPUTER

### KIOSK **ESSENTIALS**

black **75079**

28"L 28"D 40.5"H

(Computer not included.)



## DISPLAY

### COUNTER **ESSENTIALS**

black **72056**

24"W 49"L 42"H



DISPLAY

## ITEMS PICTURED BELOW

Ottoman Bench | 815120 | **Page 6**

Powered Locking Pedestal, 36" | 85061 | **Page 23**



# ACCESSORIES

We know that every exhibit is different and requires certain pieces that may be hard to find. That's why we offer an assortment of accessories that will meet your needs, from literature racks to bulletin boards to refrigerators and file cabinets. No matter the requirement, your exhibit will always stand out with these striking and functional pieces.

## TABLET STAND

**MOBILE TABLET STAND** *SELECT*

white **850714**

black **850715**

14"L 13"D 44.5"H

The Mobile Tablet Stand will adjust to fit any tablet with dimensions of at least 6.75"x 9.375" but not larger than 8.5"x 2.5", including Apple iPad, Samsung Galaxy Tab and Lenovo IdeaPad.



## TABLET STAND ACCESSORIES

**BROCHURE HOLDER\*** *SELECT*

black **850711**

8.625"L 1.1"D 11.325"H

**WIRELESS PRINTER HOLDER\*** *SELECT*

black **850712**

3.3"L 1.9"D 5.28"H

**CHARGING SHELF\*** *SELECT*

black **850713**

14.85"L 7.17"D 1"H



*\*To be ordered with the tablet stand*



ACCESSORIES

**CHROME STANCHION WITH 8' RETRACTABLE BELT** *ESSENTIALS*  
220121

42"H

**CHROME SIGN HOLDER** *ESSENTIALS*  
220118

Holds 22" x 28" sign

**ROUND LITERATURE RACK** *ESSENTIALS*  
750135

17"W | 17"L | 57"H

Revolving black display holds printed materials for easy access from 20 pockets.



**FLAT LITERATURE RACK** *ESSENTIALS*  
750136

10"W | 55"H

Forward-facing black display presents printed materials in six pockets.

**CHROME COAT TREE** *ESSENTIALS*  
220109

**ALUMINIUM EASEL** *ESSENTIALS*  
220134

**CHROME BAG RACK** *ESSENTIALS*  
220110

**SPECIAL DRAPING** (not pictured)

Special drape is available in a variety of colors. Refer to the order form for details.



ACCESSORIES



**FLOOR-STANDING BULLETIN BOARD** *ESSENTIALS*  
10201484

48"W | 96"L | 78"H



**CORRUGATED WASTEBASKET** *ESSENTIALS*  
220106



**WASTEBASKET** *ESSENTIALS*  
wastebasket color may vary.  
220107

# FREEMAN

841 Joseph E Lowery Blvd N W  
 Atlanta, GA 30318  
 (404) 253-6494 Fax: (469) 621-5610  
 FreemanAtlantaES@freeman.com

ONLINE PRICE  
 DISCOUNT PRICE  
 DEADLINE DATE  
 AUGUST 21, 2017

INCLUDE THE FREEMAN METHOD OF  
 PAYMENT FORM WITH YOUR ORDER

NAME OF SHOW: **IBTTA 85th ANNUAL MEETING / SEPTEMBER 10 - 13, 2017**

COMPANY NAME: \_\_\_\_\_ BOOTH #: \_\_\_\_\_ BOOTH SIZE: \_\_\_\_\_ X

CONTACT NAME : \_\_\_\_\_ PHONE #: \_\_\_\_\_

E-MAIL ADDRESS : \_\_\_\_\_

For Assistance, please call (404) 253-6494 to speak with one of our experts.

For fast, easy ordering, go to [www.freeman.com](http://www.freeman.com)

Qty	Part #	Description	Online Price	Discount Price	Standard Price	Total
<b>SEATING</b>						
<b>Naples Group - Black Leather</b>						
_____	810119*	Chair.....	390.50	429.55	546.70	_____
_____	830120*	Loveseat.....	523.70	576.05	733.20	_____
_____	830119*	Sofa.....	581.10	639.20	813.55	_____
<b>Heathrow Group -Black Leather</b>						
_____	810116*	Armless Chair.....	295.70	325.25	414.00	_____
_____	810117*	Corner Chair.....	344.70	379.15	482.60	_____
_____	830116*	Sofa.....	500.70	550.75	701.00	_____
<b>South Beach Group - Platinum Suede</b>						
_____	8301*	Sofa.....	542.35	596.60	759.30	_____
_____	8151*	Ottoman.....	237.00	260.70	331.80	_____
<b>Key Largo Group - Black Fabric</b>						
_____	830950*	Loveseat.....	398.15	437.95	557.40	_____
_____	830951*	Sofa.....	440.65	484.70	616.90	_____
_____	810950*	Chair.....	314.00	345.40	439.60	_____
<b>Allegro Group - Blue Fabric</b>						
_____	81019*	Chair.....	427.80	470.60	598.90	_____
_____	83015*	Sofa.....	682.90	751.20	956.05	_____
<b>Fairfax Group - White Vinyl</b>						
_____	810949*	Chair.....	264.80	291.30	370.70	_____
_____	830949*	Sofa.....	422.60	464.85	591.65	_____
<b>Hopi Group - Gray Linen</b>						
_____	810140*	Chair.....	168.50	185.35	235.90	_____
_____	830150*	Sofa.....	215.25	236.80	301.35	_____
<b>Tangiers Group - Beige Fabric</b>						
_____	810118*	Chair.....	346.05	380.65	484.45	_____
_____	830118*	Sofa.....	484.90	533.40	678.85	_____
<b>Roma Group - White Vinyl</b>						
_____	81020*	Chair.....	478.80	526.70	670.30	_____
_____	83016*	Sofa.....	734.00	807.40	1,027.60	_____

## CASUAL SEATING

<b>Ottomans</b>						
_____	815122*	Endless Square - White Leather.....	250.40	275.45	350.55	_____
_____	815123*	Endless Square - Black Leather.....	250.40	275.45	350.55	_____
_____	815953*	Endless Curved - White Leather.....	327.10	359.80	457.95	_____
_____	815952*	Endless Curved - Black Leather.....	327.10	359.80	457.95	_____
_____	815120*	Bench - White Leather.....	301.20	331.30	421.70	_____
_____	815121*	Bench - Black Leather.....	301.20	331.30	421.70	_____
_____	815119*	Half-Bench - White Vinyl.....	267.70	294.45	374.80	_____

FREEMAN furnishings

Take advantage of the Online price  
 by ordering at [www.freeman.com](http://www.freeman.com)  
 before AUGUST 21, 2017

NAME OF SHOW: **IBTTA 85th ANNUAL MEETING / SEPTEMBER 10 - 13, 2017**

COMPANY NAME: \_\_\_\_\_ BOOTH #: \_\_\_\_\_ BOOTH SIZE: **X**

CONTACT NAME : \_\_\_\_\_ PHONE #: \_\_\_\_\_

E-MAIL ADDRESS : \_\_\_\_\_

For Assistance, please call (404) 253-6494 to speak with one of our experts.

**For fast, easy ordering, go to [www.freeman.com](http://www.freeman.com)**

Qty	Part #	Description	Online Price	Discount Price	Standard Price	Total
<b>CASUAL SEATING</b>						
_____	81518*	Vibe - Blue Vinyl.....	121.70	133.85	170.40	_____
_____	81519*	Vibe - Red Vinyl.....	121.70	133.85	170.40	_____
_____	81525*	Vibe - Orange Vinyl.....	121.70	133.85	170.40	_____
_____	81520*	Vibe - Pink Vinyl.....	121.70	133.85	170.40	_____
_____	81517*	Vibe - Yellow Vinyl.....	121.70	133.85	170.40	_____
_____	81530*	Vibe - Black Vinyl.....	94.55	104.00	132.35	_____
_____	81531*	Vibe - White Vinyl.....	94.55	104.00	132.35	_____
_____	815151*	Marche Swivel Ottoman - Gray Fabric.....	166.10	182.70	232.55	_____
_____	815154*	Marche Swivel Ottoman - Red Fabric.....	166.10	182.70	232.55	_____
_____	815159*	Marche Swivel Ottoman - Blue Fabric.....	166.10	182.70	232.55	_____
_____	815152*	Marche Swivel Ottoman - Linen Fabric.....	166.10	182.70	232.55	_____
_____	815157*	Marche Swivel Ottoman - Meadow Green Fabric.....	166.10	182.70	232.55	_____
_____	815158*	Marche Swivel Ottoman - Pear Yellow Fabric.....	166.10	182.70	232.55	_____
_____	815156*	Marche Swivel Ottoman - Plum Fabric.....	166.10	182.70	232.55	_____
_____	815153*	Marche Swivel Ottoman - Raspberry Fabric.....	166.10	182.70	232.55	_____
_____	815155*	Marche Swivel Ottoman - Rose Quartz Fabric.....	166.10	182.70	232.55	_____
_____	815150*	Marche Swivel Ottoman - White Vinyl.....	166.10	182.70	232.55	_____
_____	81526*	Edge LED Cube - High Density Plastic.....	166.10	182.70	232.55	_____
<b>Banquettes</b>						
_____	8506*	Banquette, Center Cone w/Electrical Charging Outlet	451.50	496.65	632.10	_____
_____	8507*	Banquette, Quarter Curve Ottoman.....	298.50	328.35	417.90	_____
<b>Occasional Chairs</b>						
_____	71089	Black Diamond Side Chair.....	143.25	157.60	200.55	_____
_____	71090	Black Diamond Arm Chair.....	164.90	181.40	230.85	_____
_____	71091	Diva Chair.....	200.95	221.05	281.35	_____
_____	210108	Limerick® Chair by Herman Miller.....	77.15	84.85	108.00	_____
_____	8102*	Madrid Chair - Black Leather/Chrome.....	677.55	745.30	948.55	_____
_____	810816*	Madrid Chair - White Leather/Chrome.....	677.55	745.30	948.55	_____
_____	810948*	Meeting Chair - White Vinyl.....	218.05	239.85	305.25	_____
_____	810835*	Meeting Chair - Espresso Bonded Leather.....	175.50	193.05	245.70	_____
_____	810836*	Meeting Chair - Taupe Microfiber.....	230.20	253.20	322.30	_____
_____	8103*	Tub Chair - Black Fabric.....	338.85	372.75	474.40	_____
_____	810843*	Madden Chair - Light Gray Vinyl.....	358.55	394.40	501.95	_____
_____	810814*	ICE Side Chair - Transparent/Chrome.....	178.70	196.55	250.20	_____
_____	810131*	Malba Chair - Gray Molded Plastic.....	74.70	82.15	104.60	_____
_____	810130*	Malba Chair - Green Molded Plastic.....	71.85	79.05	100.60	_____
_____	810846*	Christopher Chair - White Vinyl/Chrome.....	97.15	106.85	136.00	_____
_____	810851*	Zenith Chair - White/Chrome.....	116.20	127.80	162.70	_____
_____	810841*	Rustique Chair with Arms.....	97.15	106.85	136.00	_____
_____	810837*	Razor Armless Chair - White High Density Plastic....	47.15	51.85	66.00	_____
_____	810875*	Swanson Chair - White Vinyl.....	212.80	234.10	297.90	_____
_____	810811*	Berlin Stack Chair - White & Red Plastic/Chrome....	91.85	101.05	128.60	_____
_____	810810*	Berlin Stack Chair - White & Black Plastic/Chrome...	91.85	101.05	128.60	_____
_____	810847*	Wendy Chair - Clear Acrylic.....	95.50	105.05	133.70	_____

**FREEMAN** furnishings

Take advantage of the Online price  
by ordering at [www.freeman.com](http://www.freeman.com)  
before **AUGUST 21, 2017**

NAME OF SHOW: **IBTTA 85th ANNUAL MEETING / SEPTEMBER 10 - 13, 2017**

COMPANY NAME: \_\_\_\_\_ BOOTH #: \_\_\_\_\_ BOOTH SIZE: X

CONTACT NAME : \_\_\_\_\_ PHONE #: \_\_\_\_\_

E-MAIL ADDRESS : \_\_\_\_\_

For Assistance, please call (404) 253-6494 to speak with one of our experts.

**For fast, easy ordering, go to [www.freeman.com](http://www.freeman.com)**

Qty	Part #	Description	Online Price	Discount Price	Standard Price	Total
<b>Conference Chairs</b>						
_____	71046	Gray Gaslift Chair With Arms.....	218.40	240.25	305.75	_____
_____	71045	Gray Gaslift Chair Without Arms.....	187.05	205.75	261.85	_____
_____	810874*	Labrea Chair - Charcoal Gray Fabric.....	249.85	274.85	349.80	_____
_____	81063*	Altura Conference/Guest Chair - Black Fabric/Black Steel.....	271.80	299.00	380.50	_____
_____	810807*	Luxor Executive Chair - Black Leather.....	359.90	395.90	503.85	_____
_____	810844*	Pro Executive High Back Chair - White Vinyl.....	221.30	243.45	309.80	_____
_____	810946*	Pro Executive High Back Chair - Black Vinyl.....	218.00	239.80	305.20	_____
_____	810945*	Pro Executive Mid Back Chair - White Vinyl.....	270.50	297.55	378.70	_____
_____	810944*	Pro Executive Mid Back Chair - Black Vinyl.....	270.50	297.55	378.70	_____
_____	810947*	Pro Executive Guest Chair - Black Vinyl.....	282.10	310.30	394.95	_____
<b>Bars &amp; Bar Stools</b>						
_____	8501*	Martini Bar.....	1,186.35	1,305.00	1,660.90	_____
_____	71088	Black Diamond Stool.....	194.50	213.95	272.30	_____
_____	71048	Gray Gaslift Stool with Arms.....	273.15	300.45	382.40	_____
_____	71047	Gray Gaslift Stool without Arms.....	243.90	268.30	341.45	_____
_____	71092	Diva Counter Stool.....	231.70	254.85	324.40	_____
_____	210109	Limerick® Stool by Herman Miller.....	131.90	145.10	184.65	_____
_____	810872*	Lift Hydraulic Barstool - Gray Vinyl/Chrome.....	128.80	141.70	180.30	_____
_____	810873*	Lift Hydraulic Barstool - Red Vinyl/Chrome.....	128.80	141.70	180.30	_____
_____	810871*	Lift Hydraulic Barstool - Black Vinyl/Chrome.....	128.80	141.70	180.30	_____
_____	810870*	Lift Hydraulic Barstool - White Vinyl/Chrome.....	128.80	141.70	180.30	_____
_____	33010*	Apex Barstool - Black Vinyl.....	157.70	173.45	220.80	_____
_____	3309*	Apex Barstool - Blue Ultra Suede.....	157.70	173.45	220.80	_____
_____	33042*	Apex Barstool - Red Vinyl.....	157.70	173.45	220.80	_____
_____	33043*	Apex Barstool - White Vinyl.....	157.70	173.45	220.80	_____
_____	810103*	Banana Barstool - White Vinyl/Chrome.....	161.30	177.45	225.80	_____
_____	810104*	Banana Barstool - Black Vinyl/Chrome.....	161.30	177.45	225.80	_____
_____	810850*	Zenith Barstool - White/Chrome.....	116.20	127.80	162.70	_____
_____	810840*	Zoey Barstool - White Vinyl/Chrome.....	250.95	276.05	351.35	_____
_____	810834*	Zoey Barstool - Black Vinyl/Chrome.....	250.95	276.05	351.35	_____
_____	810848*	Christopher Barstool - White.....	161.90	178.10	226.65	_____
_____	810815*	ICE Barstool - Transparent/Chrome.....	191.15	210.25	267.60	_____
_____	810202*	Shark Swivel Barstool - White Plastic/Chrome.....	286.50	315.15	401.10	_____
_____	810839*	Rustique Barstool - Gunmetal.....	97.15	106.85	136.00	_____
_____	810505*	Gin Barstool - Maple Wood/Chrome.....	142.80	157.10	199.90	_____
_____	810200*	Oslo Barstool - Blue Plastic/Chrome.....	203.60	223.95	285.05	_____
_____	810201*	Oslo Barstool - White Plastic/Chrome.....	203.60	223.95	285.05	_____

**FREEMAN** furnishings

Take advantage of the Online price  
by ordering at [www.freeman.com](http://www.freeman.com)  
before AUGUST 21, 2017

NAME OF SHOW: **IBTTA 85th ANNUAL MEETING / SEPTEMBER 10 - 13, 2017**

COMPANY NAME: \_\_\_\_\_ BOOTH #: \_\_\_\_\_ BOOTH SIZE: **X**

CONTACT NAME : \_\_\_\_\_ PHONE #: \_\_\_\_\_

E-MAIL ADDRESS : \_\_\_\_\_

For Assistance, please call (404) 253-6494 to speak with one of our experts.

**For fast, easy ordering, go to [www.freeman.com](http://www.freeman.com)**

Qty	Part #	Description	Online Price	Discount Price	Standard Price	Total
-----	--------	-------------	--------------	----------------	----------------	-------

**Draped Tables & Counters**

**Draped Tables** - Tables are 24" wide

Black  Blue  Brown  Green  Flax

Gold  Gray  Plum  Red  White

_____	124330	Draped Table 3'L x 30"H.....	118.90	130.80	166.45	_____
_____	124430	Draped Table 4'L x 30"H.....	143.25	157.60	200.55	_____
_____	124630	Draped Table 6'L x 30"H.....	167.60	184.35	234.65	_____
_____	124830	Draped Table 8'L x 30"H.....	191.90	211.10	268.65	_____
_____	12404630	4th Side Drape 6'L x 30"H.....	54.30	59.75	76.00	_____
_____	12404830	4th Side Drape 8'L x 30"H.....	54.30	59.75	76.00	_____
_____	124342	Draped Counter 3'L x 42"H.....	161.45	177.60	226.05	_____
_____	124442	Draped Counter 4'L x 42"H.....	185.80	204.40	260.10	_____
_____	124642	Draped Counter 6'L x 42"H.....	210.15	231.15	294.20	_____
_____	124842	Draped Counter 8'L x 42"H.....	234.45	257.90	328.25	_____
_____	12404642	4th Side Drape 6'L x 42"H.....	54.30	59.75	76.00	_____
_____	12404842	4th Side Drape 8'L x 42"H.....	54.30	59.75	76.00	_____

**Undraped Tables & Counters**

**Undraped Tables** - Tables are 24" wide

_____	125330	Undraped Table 3'L x 30"H.....	59.40	65.35	83.15	_____
_____	125430	Undraped Table 4'L x 30"H.....	66.65	73.30	93.30	_____
_____	125630	Undraped Table 6'L x 30"H.....	76.45	84.10	107.05	_____
_____	125830	Undraped Table 8'L x 30"H.....	84.90	93.40	118.85	_____
_____	125342	Undraped Counter 3'L x 42"H.....	84.90	93.40	118.85	_____
_____	125442	Undraped Counter 4'L x 42"H.....	101.85	112.05	142.60	_____
_____	125642	Undraped Counter 6'L x 42"H.....	119.00	130.90	166.60	_____
_____	125842	Undraped Counter 8'L x 42"H.....	135.95	149.55	190.35	_____

**Table Top Risers - Risers are 8" wide**

_____	1504100	Black 4'L x 7"H Corrugated Riser.....	31.60	34.75	44.25	_____
_____	1504101	White 4'L x 7"H Corrugated Riser.....	31.60	34.75	44.25	_____
_____	1506100	Black 6'L x 7"H Corrugated Riser.....	37.00	40.70	51.80	_____
_____	1506101	White 6'L x 7"H Corrugated Riser.....	37.00	40.70	51.80	_____
_____	1508100	Black 8'L x 7"H Corrugated Riser.....	42.75	47.05	59.85	_____
_____	1508101	White 8'L x 7"H Corrugated Riser.....	42.75	47.05	59.85	_____
_____	1504200	Black 4'L x 14"H Corrugated Riser.....	48.40	53.25	67.75	_____
_____	1504201	White 4'L x 14"H Corrugated Riser.....	48.40	53.25	67.75	_____
_____	1506200	Black 6'L x 14"H Corrugated Riser.....	59.25	65.20	82.95	_____
_____	1506201	White 6'L x 14"H Corrugated Riser.....	59.25	65.20	82.95	_____
_____	1508200	Black 8'L x 14"H Corrugated Riser.....	70.05	77.05	98.05	_____
_____	1508201	White 8'L x 14"H Corrugated Riser.....	70.05	77.05	98.05	_____

**Pedestal Tables - SoHo Series**

_____	72069	Black Top Cafe - 30"H x 24"W.....	260.75	286.85	365.05	_____
_____	72067	Black Top Cafe - 30"H x 36"W.....	260.75	286.85	365.05	_____
_____	72066	Black Top Mini - 18"H x 18"W.....	154.55	170.00	216.35	_____
_____	72070	Black Top Bistro - 42"H x 24"W.....	260.75	286.85	365.05	_____
_____	72068	Black Top Bistro - 42"H x 36"W.....	260.75	286.85	365.05	_____

**FREEMAN** furnishings

Take advantage of the Online price  
by ordering at [www.freeman.com](http://www.freeman.com)  
before AUGUST 21, 2017

NAME OF SHOW: **IBTTA 85th ANNUAL MEETING / SEPTEMBER 10 - 13, 2017**

COMPANY NAME: \_\_\_\_\_ BOOTH #: \_\_\_\_\_ BOOTH SIZE: **X**

CONTACT NAME : \_\_\_\_\_ PHONE #: \_\_\_\_\_

E-MAIL ADDRESS : \_\_\_\_\_

For Assistance, please call (404) 253-6494 to speak with one of our experts.

**For fast, easy ordering, go to [www.freeman.com](http://www.freeman.com)**

Qty	Part #	Description	Online Price	Discount Price	Standard Price	Total
<b>Pedestal Tables - Chelsea Series - Butcher Block Top</b>						
_____	72063	Butcher Block Top Cafe Table - 30"H x 30"W.....	199.20	219.10	278.90	_____
_____	72064	Butcher Block Top Cafe Table - 30"H x 36"W.....	199.20	219.10	278.90	_____
_____	720163	Butcher Block Top Bistro Table - 42"H x 30"W.....	199.20	219.10	278.90	_____
_____	720164	Butcher Block Top Bistro Table - 42"H x 36"W.....	199.20	219.10	278.90	_____
<b>Pedestal Tables</b>						
_____	820232*	Standard Base Cafe Table - Liquid White.....	219.85	241.85	307.80	_____
_____	8201203*	Standard Base Cafe Table - Blue Steel.....	219.85	241.85	307.80	_____
_____	820231*	Standard Base Bar Table - Liquid White.....	219.85	241.85	307.80	_____
_____	8201204*	Standard Base Bar Table - Blue Steel.....	219.85	241.85	307.80	_____
_____	820224*	Hydraulic Base Cafe Table - Liquid White.....	295.35	324.90	413.50	_____
_____	820230*	Hydraulic Base Bar Table - Liquid White.....	295.35	324.90	413.50	_____
_____	820241*	Madison Hydraulic Base Cafe Table - Gray Acajou.	230.30	253.35	322.40	_____
_____	820240*	Madison Hydraulic Base Bar Table - Gray Acajou..	230.30	253.35	322.40	_____
_____	820265*	Madison Cafe Table - Gray Acajou.....	181.80	200.00	254.50	_____
_____	820264*	Madison Bar Table - Gray Acajou.....	199.05	218.95	278.65	_____
<b>Occasional End &amp; Cocktail Tables</b>						
_____	115104	Studio Black End Table.....	96.75	106.45	135.45	_____
_____	115103	Studio Black Cocktail Table.....	96.75	106.45	135.45	_____
_____	82015*	Silverado End Table - Tempered Glass/Painted Steel	217.20	238.90	304.10	_____
_____	82014*	Silverado Table - Tempered Glass/Painted Steel....	230.85	253.95	323.20	_____
_____	820252*	Alondra End Table - Glass/Chrome.....	168.50	185.35	235.90	_____
_____	820250*	Alondra Cocktail Table - Glass/Chrome.....	233.75	257.15	327.25	_____
_____	820253*	Alondra End Table - Wood/Chrome.....	168.50	185.35	235.90	_____
_____	820251*	Alondra Cocktail Table - Wood/Chrome.....	233.75	257.15	327.25	_____
_____	82028*	Geo End Table - Wood/Black Steel.....	199.50	219.45	279.30	_____
_____	82027*	Geo Cocktail Table - Wood/Black Steel.....	203.75	224.15	285.25	_____
_____	82035*	Geo End Table - Glass/Chrome.....	196.05	215.65	274.45	_____
_____	82034*	Geo Cocktail Table - Glass/Chrome.....	217.20	238.90	304.10	_____
_____	82054*	Sydney End Table - Black Laminate/Brushed Steel..	202.30	222.55	283.20	_____
_____	82055*	Sydney End Table - White Laminate/Brushed Steel..	202.30	222.55	283.20	_____
_____	82052*	Sydney Table - Black Laminate/Brushed Steel.....	244.50	268.95	342.30	_____
_____	82053*	Sydney Table - White Laminate/Brushed Steel.....	244.50	268.95	342.30	_____
_____	82088*	Oliver End Table - Walnut Finish.....	180.50	198.55	252.70	_____
_____	82087*	Oliver Table - Walnut Finish.....	203.75	224.15	285.25	_____
_____	82075*	Regis End Table - Brushed Metal.....	183.60	201.95	257.05	_____
_____	82074*	Regis Bench Table - Brushed Metal.....	259.65	285.60	363.50	_____
_____	820844*	Aura Round Table - White Metal.....	103.55	113.90	144.95	_____
_____	82057*	Edge LED Lighted Table-White Plastic/Clear Acrylic	166.10	182.70	232.55	_____
_____	82043*	Geo Square-Round Table - Glass/Black Steel.....	297.85	327.65	417.00	_____
_____	82044*	Geo Square-Round Table - Glass/Chrome.....	297.85	327.65	417.00	_____
<b>Conference Tables</b>						
_____	82041*	Geo Conference Table - Glass/Black Steel.....	366.10	402.70	512.55	_____
_____	82051*	Geo Conference Table - Glass/Chrome.....	366.10	402.70	512.55	_____
_____	820260*	Madison Conference Table - Gray Acajou.....	311.30	342.45	435.80	_____

**FREEMAN** furnishings

Take advantage of the Online price  
by ordering at [www.freeman.com](http://www.freeman.com)  
before AUGUST 21, 2017

NAME OF SHOW: **IBTTA 85th ANNUAL MEETING / SEPTEMBER 10 - 13, 2017**

COMPANY NAME: \_\_\_\_\_ BOOTH #: \_\_\_\_\_ BOOTH SIZE: **X**

CONTACT NAME : \_\_\_\_\_ PHONE #: \_\_\_\_\_

E-MAIL ADDRESS : \_\_\_\_\_

For Assistance, please call (404) 253-6494 to speak with one of our experts.

**For fast, easy ordering, go to [www.freeman.com](http://www.freeman.com)**

Qty	Part #	Description	Online Price	Discount Price	Standard Price	Total
_____	820261*	Madison 5' Conference Table - Gray Acajou.....	377.10	414.80	527.95	_____
_____	820262*	Madison 8' Conference Table - Gray Acajou.....	753.15	828.45	1,054.40	_____
_____	820263*	Madison 10' Conference Table - Gray Acajou.....	753.15	828.45	1,054.40	_____
_____	82058*	Communal Table 30"H (Maple with Grommets).....	413.25	454.60	578.55	_____
_____	82059*	Communal Table 42"H (Maple with Grommets).....	579.25	637.20	810.95	_____
_____	82067*	Communal Table 30"H Maple.....	413.25	454.60	578.55	_____
_____	82068*	Communal Table 42"H Maple.....	579.25	637.20	810.95	_____
_____	82063*	Communal Table 30"H White.....	413.25	454.60	578.55	_____
_____	82066*	Communal Table 42"H White.....	579.25	637.20	810.95	_____
_____	820708*	42" Round Conference Table - White Laminate.....	325.05	357.55	455.05	_____
_____	820203*	6' Oval Conference Table - Graphite Nebula.....	428.95	471.85	600.55	_____
_____	820115*	8' Rectangular Conference Table - Granite.....	509.35	560.30	713.10	_____

**Computer Desk/Tables**

_____	84075*	Madison Desk - Gray Acajou.....	461.10	507.20	645.55	_____
_____	84077*	Madison Credenza - Gray Acajou.....	384.30	422.75	538.00	_____
_____	84078*	Madison Bookcase - Gray Acajou.....	327.65	360.40	458.70	_____
_____	820706*	Work Desk - White Laminate.....	280.05	308.05	392.05	_____
_____	820707*	Merlin Table - Gray Laminate.....	291.30	320.45	407.80	_____

**POWERED**

**Powered Seating**

_____	810120*	Naples Chair, Powered - Black Vinyl.....	532.70	585.95	745.80	_____
_____	830122*	Naples Loveseat, Powered - Black Vinyl.....	715.20	786.70	1,001.30	_____
_____	830121*	Naples Sofa, Powered - Black Vinyl.....	823.35	905.70	1,152.70	_____
_____	81021*	Roma Chair, Powered - White Vinyl.....	532.70	585.95	745.80	_____
_____	83017*	Roma Sofa, Powered - White Vinyl.....	823.35	905.70	1,152.70	_____

**Powered Tables**

_____	82070*	G30 Cocktail Table 18" H, Powered - White Top.....	350.15	385.15	490.20	_____
_____	82071*	G30 Cafe Table 30" H, Powered - White Top.....	485.35	533.90	679.50	_____
_____	82072*	G30 Bar Table 42" H, Powered - White Top.....	634.10	697.50	887.75	_____
_____	84083*	Tech Desk w/3 Drawer File Cabinet, Powered - Black Metal.....	476.90	524.60	667.65	_____
_____	84084*	Tech Desk, Powered - Black Metal.....	418.25	460.10	585.55	_____
_____	82076*	Sydney Cocktail Table, Powered Black.....	323.75	356.15	453.25	_____
_____	82073*	Sydney Cocktail Table, Powered White.....	323.75	356.15	453.25	_____

**Powered Products Pedestals**

_____	85060*	Powered Locking Pedestal 36" H, Black.....	388.30	427.15	543.60	_____
_____	85061*	Powered Locking Pedestal 36" H, White.....	388.30	427.15	543.60	_____
_____	85062*	Powered Locking Pedestal 42" H, Black.....	464.00	510.40	649.60	_____
_____	85063*	Powered Locking Pedestal 42" H, White.....	464.00	510.40	649.60	_____

**Adapters**

_____	850800*	4-Way Charging Adapter - Black.....	21.65	23.80	30.30	_____
_____	850801*	4-Way Charging Adapter - White.....	21.65	23.80	30.30	_____

**DISPLAY & ACCESSORIES**

**Product Storage**

_____	84080*	3 Door File Cabinet on Castors - Black .....	145.55	160.10	203.75	_____
_____	74082	File Cabinet w/Lock - Two Drawer - Standard Size...	139.35	153.30	195.10	_____
_____	74081	File Cabinet w/Lock - Four Drawer - Standard Size..	183.10	201.40	256.35	_____

NAME OF SHOW: **IBTTA 85th ANNUAL MEETING / SEPTEMBER 10 - 13, 2017**

COMPANY NAME: \_\_\_\_\_ BOOTH #: \_\_\_\_\_ BOOTH SIZE: X

CONTACT NAME : \_\_\_\_\_ PHONE #: \_\_\_\_\_

E-MAIL ADDRESS : \_\_\_\_\_

For Assistance, please call (404) 253-6494 to speak with one of our experts.

**For fast, easy ordering, go to [www.freeman.com](http://www.freeman.com)**

Qty	Part #	Description	Online Price	Discount Price	Standard Price	Total																		
<b>Refrigerator</b>																								
_____	75057	Small Refrigerator.....	452.85	498.15	634.00	_____																		
_____	8503001*	Refrigerator - White.....	671.30	738.45	939.80	_____																		
<b>Lighting</b>																								
_____	850707*	Mason Table Lamp - White/Brushed Silver.....	133.50	146.85	186.90	_____																		
_____	850708*	Mason Floor Lamp - White/Brushed Silver.....	198.30	218.15	277.60	_____																		
<b>Display</b>																								
_____	75020	Display Cylinder - Black - Low.....	220.55	242.60	308.75	_____																		
_____	75021	Display Cylinder - Black - Medium.....	255.25	280.80	357.35	_____																		
_____	75022	Display Cylinder - Black - High.....	292.95	322.25	410.15	_____																		
_____	75030	Display Cube - Black - 12" Small.....	231.70	254.85	324.40	_____																		
_____	75031	Display Cube - Black - 18" Medium.....	251.75	276.95	352.45	_____																		
_____	75032	Display Cube - Black - 24" Large.....	292.25	321.50	409.15	_____																		
_____	75079	Orion Computer Kiosk.....	450.60	495.65	630.85	_____																		
_____	72056	Display Counter - Black.....	371.20	408.30	519.70	_____																		
<b>Tablet Stand</b>																								
_____	850714*	Mobile Tablet Stand - White.....	237.70	261.45	332.80	_____																		
_____	850715*	Mobile Tablet Stand - Black.....	237.70	261.45	332.80	_____																		
<b>Tablet Stand Accessories</b>																								
_____	850711*	Brochure Holder - Black.....	23.60	25.95	33.05	_____																		
_____	850712*	Wireless Printer Holder - Black.....	23.60	25.95	33.05	_____																		
_____	850713*	Charging Shelf - Black.....	23.60	25.95	33.05	_____																		
<b>Accessories</b>																								
_____	220121	Chrome Stanchion w/8' Retractable Belt.....	103.55	113.90	144.95	_____																		
_____	220118	Chrome Sign Holder.....	106.75	117.45	149.45	_____																		
_____	750135	Round Literature Rack.....	261.75	287.95	366.45	_____																		
_____	750136	Flat Literature Rack.....	240.80	264.90	337.10	_____																		
_____	220109	Chrome Coat Tree.....	68.05	74.85	95.25	_____																		
_____	220134	Aluminum Easel.....	43.70	48.05	61.20	_____																		
_____	220110	Chrome Bag Rack.....	121.60	133.75	170.25	_____																		
_____	10201484	Floor Standing Bulletin Board.....	217.50	239.25	304.50	_____																		
_____	220106	Corrugated Wastebasket.....	22.90	25.20	32.05	_____																		
_____	220107	Wastebasket.....	N/A	N/A	N/A	_____																		
<b>Special Drape</b>																								
<table border="1"> <tr> <td colspan="6"><b>Special Drape</b></td> </tr> <tr> <td><input type="checkbox"/> Black</td> <td><input type="checkbox"/> Blue</td> <td><input type="checkbox"/> Brown</td> <td><input type="checkbox"/> Green</td> <td><input type="checkbox"/> Flax</td> <td></td> </tr> <tr> <td><input type="checkbox"/> Gold</td> <td><input type="checkbox"/> Gray</td> <td><input type="checkbox"/> Plum</td> <td><input type="checkbox"/> Red</td> <td><input type="checkbox"/> White</td> <td></td> </tr> </table>							<b>Special Drape</b>						<input type="checkbox"/> Black	<input type="checkbox"/> Blue	<input type="checkbox"/> Brown	<input type="checkbox"/> Green	<input type="checkbox"/> Flax		<input type="checkbox"/> Gold	<input type="checkbox"/> Gray	<input type="checkbox"/> Plum	<input type="checkbox"/> Red	<input type="checkbox"/> White	
<b>Special Drape</b>																								
<input type="checkbox"/> Black	<input type="checkbox"/> Blue	<input type="checkbox"/> Brown	<input type="checkbox"/> Green	<input type="checkbox"/> Flax																				
<input type="checkbox"/> Gold	<input type="checkbox"/> Gray	<input type="checkbox"/> Plum	<input type="checkbox"/> Red	<input type="checkbox"/> White																				
_____	12103	Special Drape 3'H (per ft.).....	20.85	22.95	29.20	_____																		
_____	12108	Special Drape 8'H (per ft.).....	28.70	31.55	40.20	_____																		

TOTAL COST		
_____	+	_____ = _____
Sub-Total	8.9% Tax	Total Cost

Taxes: Due to varying taxes across counties and cities for various categories, applicable taxes will be applied to your order accordingly based on the jurisdictions of the show city.

\*Asterisk indicates item is a Freeman Select furnishing

**FREEMAN** furnishings  
 Take advantage of the Online price by ordering at [www.freeman.com](http://www.freeman.com) before AUGUST 21, 2017



# FREEMAN

841 Joseph E. Lowery Blvd N W  
Atlanta, GA 30318  
(404) 253-6494 Fax: (469) 621-5610  
FreemanAtlantaES@freeman.com

**ONLINE PRICE  
DISCOUNT PRICE  
AUGUST 21, 2017**

**INCLUDE THE FREEMAN METHOD OF  
PAYMENT FORM WITH YOUR ORDER**

NAME OF SHOW: **IBTTA 85th ANNUAL MEETING / SEPTEMBER 10 - 13, 2017**

COMPANY NAME: \_\_\_\_\_ BOOTH #: \_\_\_\_\_



CONTACT NAME: \_\_\_\_\_ PHONE #: \_\_\_\_\_

E-MAIL ADDRESS: \_\_\_\_\_

For Assistance, please call 404-253-6494 to speak with one of our experts.

For fast, easy ordering, go to [www.freeman.com/store](http://www.freeman.com/store)

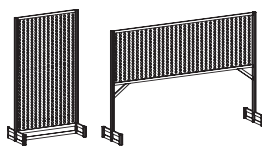
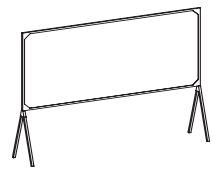
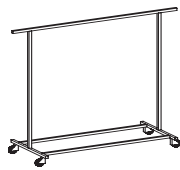
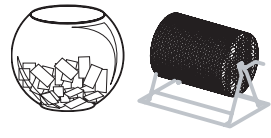
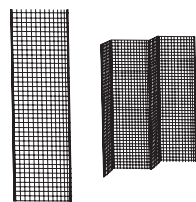
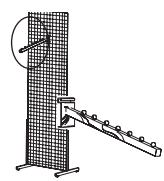
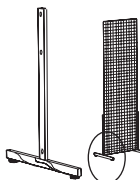
## ACCESSORIES

<p><b>PERFBOARD-SINGLE SIDED</b> Vertical      Horizontal</p> 	<p><b>BULLETIN BOARD</b></p> 	<p><b>CHROME GARMENT RACK</b></p> 	<p><b>FISH BOWL</b></p>  <p><b>TICKET TUMBLER</b></p>
<p><b>2' x 8' GRID PANELS</b></p> 	<p><b>GRID ACCESSORIES</b></p> 	<p><b>GRID LEGS</b></p> 	<p><b>2-WAY STRAIGHT ARM</b></p>  <p><b>4-WAY SLANT ARM</b></p>



**HALF VISION SHOWCASE**

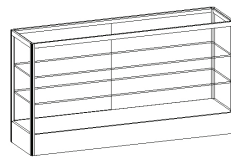

**FULL VISION SHOWCASE**

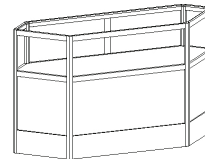

**CORNER SHOWCASE**

Qty	Part #	Description	Online Special Price	Discount Price	Standard Price	Total
<b>PERFBOARD / BULLETIN BOARDS</b>						
___	10201287	1/2M x 87" - Single Sided .....	\$132.05	145.25	184.85	___
___	10201288	1/2M x 87" - Double Sided .....	\$185.05	203.55	259.05	___
___	10201087	1M x 87" - Single Sided .....	\$210.60	231.65	294.85	___
___	10201088	1M x 87" - Double Sided .....	\$262.65	288.90	367.70	___
___	10201484	4'x8' -Bulletin Board/Horz....	\$217.50	239.25	304.50	___
<b>ACCESSORIES</b>						
___	10406	Garment Rack .....	\$101.65	111.80	142.30	___
___	15905	Fish Bowl .....	\$27.15	29.85	38.00	___
___	159011	Ticket Tumbler - small .....	\$64.15	70.55	89.80	___
___	10404	4-way Slant Arm .....	\$219.25	241.20	306.95	___
___	10403	2-way Straight Arm .....	\$171.10	188.20	239.55	___
<b>GRIDS (continued)</b>						
___	103028	Chrome - Grid .....	\$133.75	147.15	187.25	___
___	103011	White - Grid .....	\$133.75	147.15	187.25	___
___	103029	Chrome - Grid Legs .....	\$44.70	49.15	62.60	___
___	103029	White - Grid Legs .....	\$44.70	49.15	62.60	___
___	10307	7-Ball Waterfall (for grids).....	\$18.15	19.95	25.40	___

Qty	Part #	Description	Online Special Price	Discount Price	Standard Price	Total
<b>SHOWCASES</b>						
___	175561	Full Vision Case .....	\$774.80	852.30	1084.70	___
___	175560	Half Vision Case .....	\$696.35	766.00	974.90	___
___	175563	Corner Case .....	\$598.55	658.40	837.95	___
<p><b>FULL VISION CASE</b> 79 1/2"L x 20 7/16"W x 42"H Includes two plexi-glass shelves with adjustable brackets and 32 3/8" of viewing area. No storage below display area.</p> <p><b>HALF VISION CASE</b> 79 1/2"L x 20 7/16"W x 42"H Includes one plexi-glass shelf with adjustable brackets and 14 1/2" of viewing area.</p> <p><b>CORNER SHOW CASE</b> Includes an area for storage below the display surface and has 12 1/4" of viewing area.</p>						
<p><b>All showcases are 42" high and include a lightbar mounted inside the top front edge and a sliding door with lock on the back.</b></p> <p><b>Electrical service for lightbar must be arranged through the facility.</b></p>						
<b>TOTAL COST</b>						
<p><b>Sub-Total</b> _____ + <b>Tax (8.9%)</b> _____ = <b>TOTAL</b> _____</p>						

Don't see what you need?  
Please call an Exhibitor Services Representative @ 404-253-6494.

# FROM THE GROUND UP

Engage your audience from the moment they set foot in your exhibit with Freeman's custom carpets. Our colorfast carpeting boasts a consistent shade every time and the padding exceeds industry standards, ensuring that you'll be floored by the quality. Freeman's custom options include borders, patterns and logo applications in both our classic and prestige carpeting lines.

- Colorfast carpet technology guarantees a uniform and professional look throughout the life of your exhibit
- Diverse customization options guarantee the fulfillment of your brand standards
- All carpet and padding is manufactured with recycled material
- Rental prices are all-inclusive so there are never hidden charges for material handling or pickup



Call customer service at the number listed on the Quick Facts. For fast, easy ordering, go to [www.freeman.com](http://www.freeman.com)

# PRESTIGE CARPET

Freeman's prestige carpet combines plush comfort with durable soil and stain resistance, perfect for high-traffic areas. Five popular colors are available in a luxurious 40-ounce weight and all nine designer colors are available in a 28-ounce weight.

Freeman's prestige carpet packages include new 10-foot-wide carpet, delivery, Visqueen covering, installation, carpet tape, carpet removal and all carpet material handling fees. Price includes environmentally friendly disposal of carpet after usage. Foam carpet padding is available for a minimal fee. If you have a large order, please contact us to see if volume discounts may apply.

## Custom Options

Prestige carpets can also be customized to fit your exhibit needs with unique logos, patterns and borders. Call the phone number on the Quick Facts for assistance.



*black\**



*cardinal*



*charcoal\**



*cream*



*gray pearl\**



*navy\**



*toast*



*wedgewood*



*white\**

*\*Colors available in both 28 oz. and 40 oz.*

# CLASSIC CARPET

## Custom Cut

Freeman classic carpet is available in a range of colors and includes delivery, Visqueen covering, installation, carpet tape, carpet removal and all carpet material handling fees. Foam carpet padding is available for a minimal fee. If you have a large order, please contact us to see if volume discounts may apply.

## Standard Cut

Our classic carpet comes in a variety of sizes. Prices include delivery, installation, carpet tape, carpet removal and all carpet material handling fees. Foam carpet padding and Visqueen covering are available for a minimal fee.



*black*



*blue*



*gray*



*green*



*latte*



*midnight blue*



*plum*



*red*



*red pepper*



*tuxedo*

*Actual colors may vary slightly*

# FREEMAN

841 Joseph E Lowery Blvd N W  
Atlanta, GA 30318  
(404) 253-6494 Fax: (469) 621-5610  
FreemanAtlantaES@freeman.com

ONLINE PRICE  
DISCOUNT PRICE  
DEADLINE DATE  
AUGUST 21, 2017

INCLUDE THE FREEMAN METHOD OF  
PAYMENT FORM WITH YOUR ORDER

NAME OF SHOW: **IBTTA 85th ANNUAL MEETING / SEPTEMBER 10 - 13, 2017**

COMPANY NAME: \_\_\_\_\_ BOOTH #: \_\_\_\_\_ BOOTH SIZE: \_\_\_\_\_ X

CONTACT NAME : \_\_\_\_\_ PHONE #: \_\_\_\_\_

E-MAIL ADDRESS : \_\_\_\_\_

For Assistance, please call (404) 253-6494 to speak with one of our experts.

- Orders received after the deadline or without payment will be charged the Standard price.
- All utility lines must be installed before carpet installation. Utilities should be ordered in advance.
- Pricing includes delivery, material handling, installation and removal.

All carpets, padding and plastic covering contain recycled content and are recyclable.

For fast, easy ordering, go to [www.freeman.com](http://www.freeman.com)

## 10' CLASSIC CARPET , PADDING & PLASTIC COVERING

CHOOSE YOUR CARPET COLOR:

- Black  Blue  Gray  Green  Latte  Midnight Blue  Plum  Red  Red Pepper  Tuxedo

Qty	Description	Online Price	Discount Price	Standard Price	Total
_____	10' x 10' Classic Carpet .....	\$ 286.00	\$ 314.60	\$ 400.40	_____
_____	10' x 20' Classic Carpet .....	\$ 572.00	\$ 629.20	\$ 800.80	_____
_____	10' x 30' Classic Carpet .....	\$ 858.00	\$ 943.80	\$ 1,201.20	_____
_____	10' x 40' Classic Carpet .....	\$ 1,144.00	\$ 1,258.40	\$ 1,601.60	_____
_____	10' x 10' Carpet Padding - Single Layer.....	\$ 79.05	\$ 86.95	\$ 110.65	_____
_____	10' x 20' Carpet Padding - Single Layer.....	\$ 158.10	\$ 173.90	\$ 221.35	_____
_____	10' x 30' Carpet Padding - Single Layer.....	\$ 237.10	\$ 260.80	\$ 331.95	_____
_____	10' x 40' Carpet Padding - Single Layer.....	\$ 316.15	\$ 347.75	\$ 442.60	_____
_____	10' x 10' Carpet Padding - Double Layer.....	\$ 158.10	\$ 173.90	\$ 221.35	_____
_____	10' x 20' Carpet Padding - Double Layer.....	\$ 316.15	\$ 347.75	\$ 442.60	_____
_____	10' x 30' Carpet Padding - Double Layer.....	\$ 474.25	\$ 521.70	\$ 663.95	_____
_____	10' x 40' Carpet Padding - Double Layer.....	\$ 632.30	\$ 695.55	\$ 885.20	_____
_____	Plastic Covering (price per sq. ft.).....	\$ .50	\$ .55	\$ .70	_____

## 9' CLASSIC CARPET , PADDING & PLASTIC COVERING

CHOOSE YOUR CARPET COLOR:

- Black  Blue  Gray  Green  Latte  Midnight Blue  Plum  Red  Red Pepper  Tuxedo

Qty	Description	Online Price	Discount Price	Standard Price	Total
_____	9' x 10' Classic Carpet .....	\$ 183.40	\$ 201.75	\$ 256.75	_____
_____	9' x 20' Classic Carpet .....	\$ 365.35	\$ 401.90	\$ 511.50	_____
_____	9' x 30' Classic Carpet .....	\$ 548.50	\$ 603.35	\$ 767.90	_____
_____	9' x 40' Classic Carpet .....	\$ 730.00	\$ 803.00	\$ 1,022.00	_____
_____	9' x 10' Carpet Padding - Single Layer.....	\$ 71.15	\$ 78.25	\$ 99.60	_____
_____	9' x 20' Carpet Padding - Single Layer.....	\$ 142.25	\$ 156.50	\$ 199.15	_____
_____	9' x 30' Carpet Padding - Single Layer.....	\$ 213.40	\$ 234.75	\$ 298.75	_____
_____	9' x 40' Carpet Padding - Single Layer.....	\$ 284.55	\$ 313.00	\$ 398.35	_____
_____	9' x 10' Carpet Padding - Double Layer.....	\$ 142.25	\$ 156.50	\$ 199.15	_____
_____	9' x 20' Carpet Padding - Double Layer.....	\$ 284.55	\$ 313.00	\$ 398.35	_____
_____	9' x 30' Carpet Padding - Double Layer.....	\$ 426.80	\$ 469.50	\$ 597.50	_____
_____	9' x 40' Carpet Padding - Double Layer.....	\$ 569.10	\$ 626.00	\$ 796.75	_____
_____	Plastic Covering (price per sq. ft.).....	\$ .50	\$ .55	\$ .70	_____

\*\*9' carpet is laid toward the front edge, leaving 1' at the back of the booth for access to utility ports.\*\*

TOTAL COST		
Sub- Total	+	8.9% Tax
	=	Total Cost

FREEMAN standard size carpet

Take advantage of the Online price  
by ordering at [www.freeman.com](http://www.freeman.com)  
before AUGUST 21, 2017

# FREEMAN

841 Joseph E Lowery Blvd N W  
 Atlanta, GA 30318  
 (404) 253-6494 Fax: (469) 621-5610  
 FreemanAtlantaES@freeman.com

ONLINE PRICE  
 DISCOUNT PRICE  
 DEADLINE DATE  
 AUGUST 21, 2017

INCLUDE THE FREEMAN METHOD OF  
 PAYMENT FORM WITH YOUR ORDER

NAME OF SHOW: **IBTTA 85th ANNUAL MEETING / SEPTEMBER 10 - 13, 2017**

COMPANY NAME: \_\_\_\_\_ BOOTH #: \_\_\_\_\_ BOOTH SIZE: \_\_\_\_\_ X

CONTACT NAME: \_\_\_\_\_ PHONE #: \_\_\_\_\_

E-MAIL ADDRESS: \_\_\_\_\_

For Assistance, please call **(404) 253-6494** to speak with one of our experts.

- **Guaranteed new, high-quality carpet.**
- **Orders received after the deadline or without payment will be charged the Standard price and are subject to availability.**
- **Prestige and Custom Cut Classic Carpet are subject to a 100% cancellation charge.**
- **All utility lines must be installed before carpet installation. Utilities should be ordered in advance.**

All carpets, padding and plastic covering contain recycled content and are recyclable.

For fast, easy ordering, go to [www.freeman.com](http://www.freeman.com)

**CUSTOM CUT CLASSIC CARPET - includes plastic covering, delivery, material handling, installation and removal**

- Order Custom Cut Classic Carpeting by the sq. ft. if your size is not listed on the standard size order form.

Sample: Booth Size: 10 x 25 = 250 sq. ft. @ \$ **3.00**

**CHOOSE YOUR CARPET COLOR - 16 oz. Carpet:**

- Black  Blue  Gray  Green  Latte  Midnight Blue  Plum  Red  Red Pepper  Tuxedo

**16 oz. Carpet Rental** - Price per sq. ft (100 sq. ft. minimum)

Per sq. ft.	Booth Size: _____ x _____ = _____ sq. ft. @	Online Price	Discount Price	Standard Price	Total
		\$ <b>3.00</b>	\$ <b>3.30</b>	\$ <b>4.20</b>	_____

**PRESTIGE CARPET - includes plastic covering, delivery, material handling, installation and removal**

**CHOOSE YOUR CARPET COLOR - 28 oz. Carpet:**

- Black  Cardinal  Charcoal  Cream  Gray Pearl  Navy  Toast  Wedgewood  White

**28 oz. Carpet Rental** - Price per sq. ft. (100 sq. ft. minimum)

	Booth Size: _____ x _____ = _____ sq. ft. @	Online Price	Discount Price	Standard Price	Total
1 - 700 sq. ft.		\$ <b>3.50</b>	\$ <b>3.85</b>	\$ <b>4.90</b>	_____
Over 700 sq. ft.		\$ <b>3.15</b>	\$ <b>3.45</b>	\$ <b>4.40</b>	_____

**CHOOSE YOUR CARPET COLOR - 40 oz. Carpet:**

- Black  Charcoal  Gray Pearl  Navy  White

**40 oz. Carpet Rental** - Price per sq. ft. (100 sq. ft. minimum)

	Booth Size: _____ x _____ = _____ sq. ft. @	Online Price	Discount Price	Standard Price	Total
1 - 700 sq. ft.		\$ <b>4.25</b>	\$ <b>4.70</b>	\$ <b>5.95</b>	_____
Over 700 sq. ft.		\$ <b>3.90</b>	\$ <b>4.30</b>	\$ <b>5.45</b>	_____

**CARPET PADDING - includes delivery, material handling, installation and removal**

- Order Carpet Padding by the sq. ft. if your size is not listed on the standard size order form.

Sample: Booth Size: 10 x 25 = 250 sq. ft. @ \$ **.83**

Qty	Description	Price per sq. ft. (90 sq. ft. minimum)	Online Price	Discount Price	Standard Price	Total
_____	Carpet Padding -1/2" (90 - 700 sq. ft.)		\$ <b>.83</b>	\$ <b>.90</b>	\$ <b>1.15</b>	_____
_____	Carpet Padding-1/2" (Over 700 sq. ft.)		\$ <b>.58</b>	\$ <b>.65</b>	\$ <b>.80</b>	_____
_____	Double Carpet Padding - 1/2" (90 - 700 sq. ft.)		\$ <b>1.66</b>	\$ <b>1.85</b>	\$ <b>2.30</b>	_____
_____	Double Carpet Padding -1/2" (Over 700 sq. ft.)		\$ <b>1.16</b>	\$ <b>1.30</b>	\$ <b>1.60</b>	_____

TOTAL COST		
_____	+	_____
Sub- Total		8.9% Tax
	=	Total Cost

FREEMAN cut to size carpet

Take advantage of the Online price by ordering at [www.freeman.com](http://www.freeman.com) before AUGUST 21, 2017

# FREEMAN

841 Joseph E Lowery Blvd N W  
 Atlanta, GA 30318  
 (404) 253-6494 Fax: (469) 621-5610  
 FreemanAtlantaES@freeman.com

INCLUDE THE FREEMAN METHOD OF  
 PAYMENT FORM WITH YOUR ORDER

NAME OF SHOW: **IBTTA 85th ANNUAL MEETING / SEPTEMBER 10 - 13, 2017**

COMPANY NAME: \_\_\_\_\_ BOOTH #: \_\_\_\_\_ BOOTH SIZE: \_\_\_\_\_ X

CONTACT NAME : \_\_\_\_\_ PHONE #: \_\_\_\_\_

E-MAIL ADDRESS : \_\_\_\_\_

For Assistance, please call (404) 253-6494 to speak with one of our experts.

For fast, easy ordering, go to [www.freeman.com](http://www.freeman.com)

## CLEANING SERVICES

- Prices are based on total square footage of booth regardless of area to be cleaned.
- 100 sq. ft. minimum.
- Our exclusive cleaning contract for this show will not permit other service contractors, including exhibitor appointed contractors to provide this service.
- **Show Site Prices will apply to all cleaning orders placed at show site.**

### VACUUMING (per sq. ft. - 100 sq. ft. minimum)

Qty (sq. ft.)	Part #	Description	Advance Price	Show Site Price	Total
---------------	--------	-------------	---------------	-----------------	-------

- Includes emptying of your booth's wastebasket(s) at the time of vacuuming.

_____	610100	Booth Vacuuming - One Time .....	.62	.85	_____
_____	610200	Booth Vacuuming - 2 Days .....	.94	1.30	_____

### SHAMPOOING (per sq ft - 100 sq ft minimum)

Qty (sq. ft.)	Part #	Description	Advance Price	Show Site Price	Total
---------------	--------	-------------	---------------	-----------------	-------

_____	630100	Shampoo Carpet - One Time .....	.83	1.15	_____
_____	630200	Shampoo Carpet - 2 Days .....	1.45	2.05	_____

### PORTER SERVICE (per day)

Qty (# days)	Part #	Description	Advance Price	Show Site Price	Total
--------------	--------	-------------	---------------	-----------------	-------

- Includes emptying of your booth's wastebasket(s) and policing of your exhibit area at two-hour intervals during show hours.

_____	620500	Exhibit Area / Under 500 sq.ft. ....	104.10	145.75	_____
_____	6201500	Exhibit Area / 501 - 1,500 sq. ft. ....	145.90	204.25	_____
_____	6202500	Exhibit Area / 1,501 - 2,500 sq. ft. ....	184.10	257.75	_____
_____	6203500	Exhibit Area / Over 2,500 sq.ft.....			Call for Quote

### TOTAL COST

_____	+	_____	=	_____
Sub-Total		8.9 %Tax		Total Cost

FREEMAN cleaning

# FIT TO PRINT

.....

SmartFabric™ is a triple layered fabric made of 100% polyester that's ideal for printed graphics. It's an extremely versatile all-in-one fabric and has been treated to meet NFPA 701 small-scale flammability standards.



## SMARTFABRIC™ RENTAL EXHIBITS



**10 x 10 ft. unit**

**FRAME**

117"W 93.5"H



**10 x 20 ft. unit**

**FRAME**

234"W 93.5"H

**CLEAR ACRYLIC SHELF**

36"W 12"H .25"D

(up to 15lbs each)

### RENTAL EXHIBITS INCLUDE:

- Custom Fabric Graphic (item purchased to keep)
- Zippered Carrying Case for Fabric Graphic (item purchased to keep)
- Rental Frame
- 9'x10' or 9'x20' Classic Carpet (color selections on page 3)
- Exhibit Installation & Dismantle
- Exhibit Material Handling
- Nightly Vacuuming
- 2 Arm Lights per 10' Booth
- 4 Arm Lights per 20' Booth
- 2 Clear Acrylic Shelves per 10' Booth (36"x12", up to 15 lbs.)
- 4 Clear Acrylic Shelves per 20' Booth (36"x12", up to 15 lbs.)
- Power (500 watts) for LIGHTS only (and Labor to hang lights)

## FRAME ONLY UNIT

This option is available for customers who have previously rented the SmartFabric™ Rental Exhibit and are reusing their backwall graphic. Fabric from other sources will not be installed on this Freeman frame rental. If you need Freeman to create a new graphic, please select the SmartFabric™ Rental Exhibit. No fabric graphics will be provided separately from the rental unit.



**10 x 10 ft. frame**



**10 x 20 ft. frame**

### RENTAL EXHIBITS INCLUDE:

- Rental Frame
- 9'x10' or 9'x20' Classic Carpet (color selections on page 3)
- Exhibit Installation & Dismantle
- Exhibit Material Handling
- Nightly Vacuuming
- 2 Arm Lights per 10' Booth
- 4 Arm Lights per 20' Booth
- 2 Clear Acrylic Shelves per 10' Booth (36"x12", up to 15 lbs.)
- 4 Clear Acrylic Shelves per 20' Booth (36"x12", up to 15 lbs.)
- Power (500 watts) for LIGHTS only (and Labor to hang lights)



## CLASSIC CARPET

9'x10' or 9'x20' (16 oz.) – Color Options Included with Rental Package Options Above

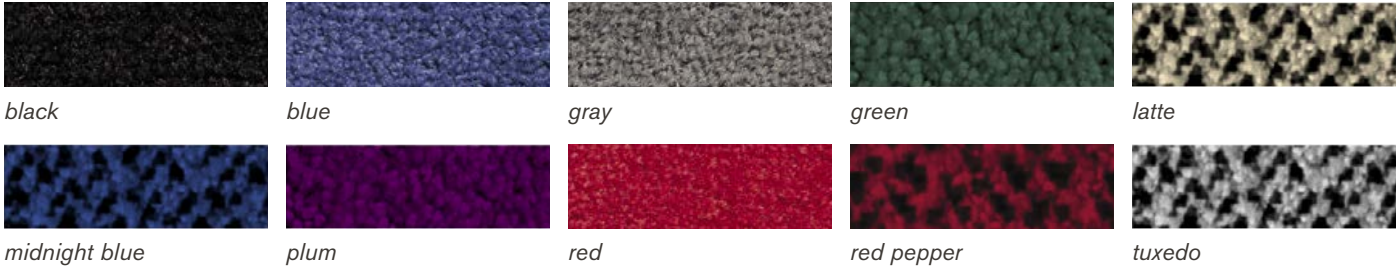

9' carpet is laid toward the front edge, leaving 1' at the back of the booth for utility port access. Actual colors may vary slightly.

## PRESTIGE CARPET

(28 oz.) – Available Upgrade Color Options



\*Colors available in both 28 oz. and 40 oz. Actual colors may vary slightly.

## ACCESSORIES

SmartFabric Rental packages include these accessories. Refer to the "Rental Exhibits Include" sections of each package. These items are available to order as additional accessories if needed.

### SMARTFABRIC ZIPPERED CARRYING CASE

20"W 8"H 16"D



### CLEAR ACRYLIC SHELF

36"W 12"H .25"D  
(up to 15lbs each)



## CUSTOM GRAPHICS

A Freeman Exhibitor Sales Specialist will contact you to review the process for providing graphic files and to review helpful tips that will ensure a successful graphic print. Freeman can custom design a graphic file for you using our graphic design services that guarantees a high resolution backwall graphic. Ask your Exhibitor Sales Specialist for more information.

### “CLEAN FOOTPRINT” BOOTH PACKAGE

When you select the “Clean Footprint” package your booth will use only materials that can be reused or recycled. All flooring, lighting, furniture and booth structure will go back into inventory to be reused again. Your personalized graphic panels used in the booth will be on a reusable and recyclable substrate.



# FREEMAN

841 Joseph E Lowery Blvd N W  
 Atlanta, GA 30318  
 (404) 253-6494 Fax: (469) 621-5610  
 FreemanAtlantaES@freeman.com

DISCOUNT PRICE  
 DEADLINE DATE  
 AUGUST 21, 2017

INCLUDE THE FREEMAN METHOD OF PAYMENT FORM WITH YOUR ORDER

NAME OF SHOW: **IBTTA 85th ANNUAL MEETING / SEPTEMBER 10 - 13, 2017**

COMPANY NAME: \_\_\_\_\_ BOOTH #: \_\_\_\_\_ BOOTH SIZE: X

CONTACT NAME : \_\_\_\_\_ PHONE #: \_\_\_\_\_

E-MAIL ADDRESS : \_\_\_\_\_

For Assistance, please call (404) 253-6494 to speak with one of our experts.

For fast, easy ordering, go to [www.freeman.com](http://www.freeman.com)

## SMARTFABRIC EXHIBIT

SmartFabric Exhibits provide a custom printed fabric graphic to keep and re-use on future events.



### SmartFabric Rental Exhibit Includes:

- 116.5" X 92.5" Custom Fabric Graphic (Purchased item to keep)
- Carrying Case for Graphic (To carry the purchased fabric graphic)
- Classic Carpet 9' X 10' or 9' X 20' (Select color below)
- Installation & Dismantle of Exhibit
- Material Handling of Exhibit
- Nightly Vacuuming
- 2-Arm Lights (per 10 ft.)
- 2 Shelves (36" x 12", supports up to 15 lbs.)
- Power (500 watts) for LIGHTS only (and Labor to hang lights)

**Classic Carpet:**  Black  Blue  Gray  Green  Latte  
 Midnight Blue  Plum  Red  Red Pepper  Tuxedo

Qty	Description	Discount	Standard	Total
_____	10' x 10' SmartFabric Exhibit.....	\$ 1,895.00	\$ 2,653.00	_____
_____	10' x 20' SmartFabric Exhibit.....	\$ 3,695.00	\$ 5,173.00	_____

## CUSTOM GRAPHICS

A Freeman Exhibitor Sales Specialist will be contacting you to review the process for providing graphic files and helpful tips that will ensure a successful graphic print.

## FRAME ONLY UNIT

The SmartFabric frame only unit is for exhibitors who have previously rented the SmartFabric exhibit (above) and have the fabric graphic ready for re-use. If you need a new graphic made, please select the SmartFabric Rental Exhibit (above). No fabric graphics will be printed without the rental unit.



### Frame Only Unit Includes:

- Classic Carpet 9' X 10' or 9' X 20' (Select color below)
- Installation & Dismantle of Exhibit
- Material Handling of Exhibit
- Nightly Vacuuming
- 2-Arm Lights (per 10 ft.)
- 2 Shelves (36" x 12", supports up to 15 lbs.)
- Power (500 watts) for LIGHTS only (and Labor to hang lights)

**Classic Carpet:**  Black  Blue  Gray  Green  Latte  
 Midnight Blue  Plum  Red  Red Pepper  Tuxedo

Qty	Description	Discount	Standard	Total
_____	10' x 10' Frame Only Unit.....	\$ 1,195.00	\$ 1,673.00	_____
_____	10' x 20' Frame Only Unit.....	\$ 1,995.00	\$ 2,793.00	_____

## ACCESSORIES

Qty	Description	Discount	Standard	Total
_____	SmartFabric Arm Light .....	\$ 65.00	\$ 91.00	_____
_____	SmartFabric Acrylic Shelf (supports up to 15 lbs).....	\$ 150.00	\$ 210.00	_____
_____	SmartFabric Carrying Case (purchase).....	\$ 20.00	\$ 28.00	_____

## QUICK TIPS

• Orders received after the deadline or without payment will be charged the Standard price and are subject to availability. All graphics are subject to a 100% cancellation charge once production begins.

The product offered has recyclable content or has eco-friendly attributes and is 100% recyclable according to manufacturer's specifications.

\*\*9' carpet is laid toward the front edge, leaving 1' at the back of the booth for access to utility ports.\*\*

TOTAL COST		
_____	+	_____ = _____
Sub-Total		8.9 % Tax Total Cost

# RENTAL EXHIBITS THAT IMPRESS

When it comes to designing your exhibit, effective solutions don't require expensive investments. Take the stress out of your upcoming show with a rental booth exhibit from Freeman. With quality rental options that meet your budget requirements, we'll have you exhibit ready at a moment's notice, without the hassle of ownership.

**PACKAGE 1**



10 X 20



10 X 10

**PACKAGE 1 UPGRADE OPTIONS**

With Graphics and Cabinet

10 X 10

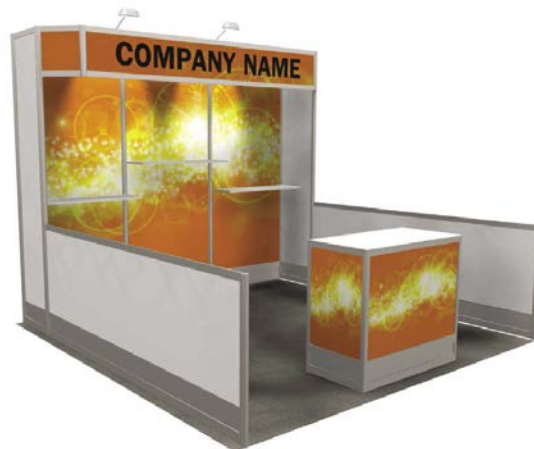

# FREEMAN

## PACKAGE 2



10 X 20



10 X 10

## PACKAGE 3



10 X 20



10 X 10

## PACKAGE 4



10 X 20



10 X 10

**PACKAGE 2 UPGRADE OPTIONS**

With Graphics and Cabinet

10 X 10



**PACKAGE 3 UPGRADE OPTIONS**

With Graphics and Cabinet

10 X 10



**PACKAGE 4 UPGRADE OPTIONS**

With Graphics and Cabinet

10 X 10



# FREEMAN

## PACKAGE 5



10 X 20



10 X 10

## PACKAGE 6



10 X 20



10 X 10

## PACKAGE 5 UPGRADE OPTIONS

With Graphics and Cabinet

10 X 10



## PACKAGE 6 UPGRADE OPTIONS

With Graphics and Cabinet

10 X 10



# FREEMAN

Other upgrade options available that allow you to change the panels to slatwall, add shelves, change the metal color and add cabinets as a storage option with the dual purpose of a reception counter.



10 X 10

**SLATWALL**



10 X 10

**COLORED PANELS**



10 X 10

**SHELVES**



10 X 10

**BLACK METAL**



**CABINETS**



## Booth Panel Options – Color Options Included with Rental Package



## Classic Carpet (16 oz.) – Color Options Included with Rental Package Options Above



9' carpet is laid toward the front edge, leaving 1' at the back of the booth for utility port access. Actual colors may vary slightly.

## Prestige Carpet (28 oz.) – Available Upgrade Color Options



\*Colors available in both 28 oz. and 40 oz. Actual colors may vary slightly.

### Rental Exhibits Include:

- 9x10 or 9x20 Classic Carpet
- Exhibit Installation & Dismantle
- Exhibit Material Handling
- Nightly Vacuuming
- 2-arm lights per 10' Booth
- Power (500 watts) for LIGHTS only (and Labor to hang lights)

### questions?

All packages can be customized or modified to fit your specific needs. To speak with an Exhibitor Sales Specialist, call the number listed on the Quick Facts.



### “CLEAN FOOTPRINT” BOOTH PACKAGE

When you select the “Clean Footprint” package your booth will use only materials that can be reused or recycled. All flooring, lighting, furniture and booth structure will go back into inventory to be reused again. Your personalized graphic panels used in the booth will be on a reusable and recyclable substrate.

# FREEMAN

841 Joseph E Lowery Blvd N W  
Atlanta, GA 30318  
(404) 253-6494 Fax: (469) 621-5610  
FreemanAtlantaES@freeman.com

DISCOUNT PRICE  
DEADLINE DATE  
AUGUST 21, 2017

INCLUDE THE FREEMAN METHOD OF PAYMENT FORM WITH YOUR ORDER

NAME OF SHOW: **IBTTA 85th ANNUAL MEETING / SEPTEMBER 10 - 13, 2017**

COMPANY NAME: \_\_\_\_\_ BOOTH #: \_\_\_\_\_ BOOTH SIZE: \_\_\_\_\_ X

CONTACT NAME : \_\_\_\_\_ PHONE #: \_\_\_\_\_

E-MAIL ADDRESS : \_\_\_\_\_

For Assistance, please call **(404) 253-6494** to speak with one of our experts.

For fast, easy ordering, go to [www.freeman.com](http://www.freeman.com)

**All Exhibits Include:** installation & dismantle of exhibit, material handling of exhibit, 9' x 10' or 9' x 20' classic carpet with nightly vacuuming, 2 arm lights (per 10' unit), power (500 watts) for lights ONLY and labor to hang arm lights.

To place your order, please check the appropriate box and complete the remaining selections at the bottom of the form.

## RENTAL EXHIBITS

		Discount Price	Standard Price		Discount Price	Standard Price	
Package 1	<input type="checkbox"/> 10' x 10'	2,808.85	3,932.40	<input type="checkbox"/> 10' x 20'	5,617.55	7,864.55	_____
Package 2	<input type="checkbox"/> 10' x 10'	1,823.55	2,552.95	<input type="checkbox"/> 10' x 20'	3,647.05	5,105.85	_____
Package 3	<input type="checkbox"/> 10' x 10'	2,373.85	3,323.40	<input type="checkbox"/> 10' x 20'	4,747.80	6,646.90	_____
Package 4	<input type="checkbox"/> 10' x 10'	2,152.30	3,013.20	<input type="checkbox"/> 10' x 20'	4,304.50	6,026.30	_____
Package 5	<input type="checkbox"/> 10' x 10'	2,091.50	2,928.10	<input type="checkbox"/> 10' x 20'	4,183.15	5,856.40	_____
Package 6	<input type="checkbox"/> 10' x 10'	2,187.00	3,061.80	<input type="checkbox"/> 10' x 20'	4,374.00	6,123.60	_____

## CHOOSE YOUR PANEL

- Black Fabric    
  Blue Fabric    
  Gray Fabric    
  White Hardwall    
  White Perfboard

## CARPET

Our Classic Carpet and nightly vacuuming are included in the price of your Rental Exhibit. The following colors are available:

Check color choice

- Black      Blue      Gray      Green      Latte  
 Midnight Blue      Plum      Red      Red Pepper      Tuxedo

You may want to add padding or upgrade your carpet to one of our 15 designer colors in our PRESTIGE carpet line. Now available in **28 oz.** and **40 oz.** weight. Refer to our enclosed Carpet order form for color selections and pricing.

## LIGHTING

Each Rental Exhibit includes 2 Arm Lights (per 10' unit).

**Note:** Power and labor to hang the lights are included in our standard rental exhibit package price. Power consumption not to exceed 500 Watts.

Additional power must be ordered separately.

## HEADER IDENTIFICATION SIGN

Indicate which color lettering you would like. We have a wide variety of standard colors available:

- Black      Blue      Brown      Burgundy      PMS Color \_\_\_\_\_  
 Red      Teal      White      Green      Font Type \_\_\_\_\_

\*Unless font type is indicated, Helvetica will be used.

Indicate exactly how you want your company name to appear:

## ENHANCE YOUR EXHIBIT

Enhance your exhibit and have an Exhibitor Sales Specialist contact you for pricing by checking any of the following boxes:

- Slatwall & Shelves      Cabinets & Counters      Specialty Colored Metal      Recyclable Graphics  
 Colored Panels      Creating a Custom Exhibit      Graphics & Custom Logo      White Eco-Board

The product offered has recyclable content or has eco-friendly attributes and is 100% recyclable according to manufacturer's specifications.

TOTAL COST		
_____	+	_____ = _____
Sub-Total		8.9 % Tax     Total Cost

# FREEMAN

841 Joseph E Lowery Blvd N W  
 Atlanta, GA 30318  
 (404) 253-6494 Fax: (469) 621-5610  
 FreemanAtlantaES@freeman.com

DISCOUNT PRICE  
 DEADLINE DATE  
 AUGUST 21, 2017

INCLUDE THE FREEMAN METHOD OF  
 PAYMENT FORM WITH YOUR ORDER

NAME OF SHOW: **IBTTA 85th ANNUAL MEETING / SEPTEMBER 10 - 13, 2017**

COMPANY NAME: \_\_\_\_\_ BOOTH #: \_\_\_\_\_ BOOTH SIZE: \_\_\_\_\_ X

CONTACT NAME : \_\_\_\_\_ PHONE #: \_\_\_\_\_

E-MAIL ADDRESS : \_\_\_\_\_

For Assistance, please call (404) 253-6494 to speak with one of our experts.

For fast, easy ordering, go to [www.freeman.com](http://www.freeman.com)  
**ACCESSORIES FOR RENTAL UNITS**

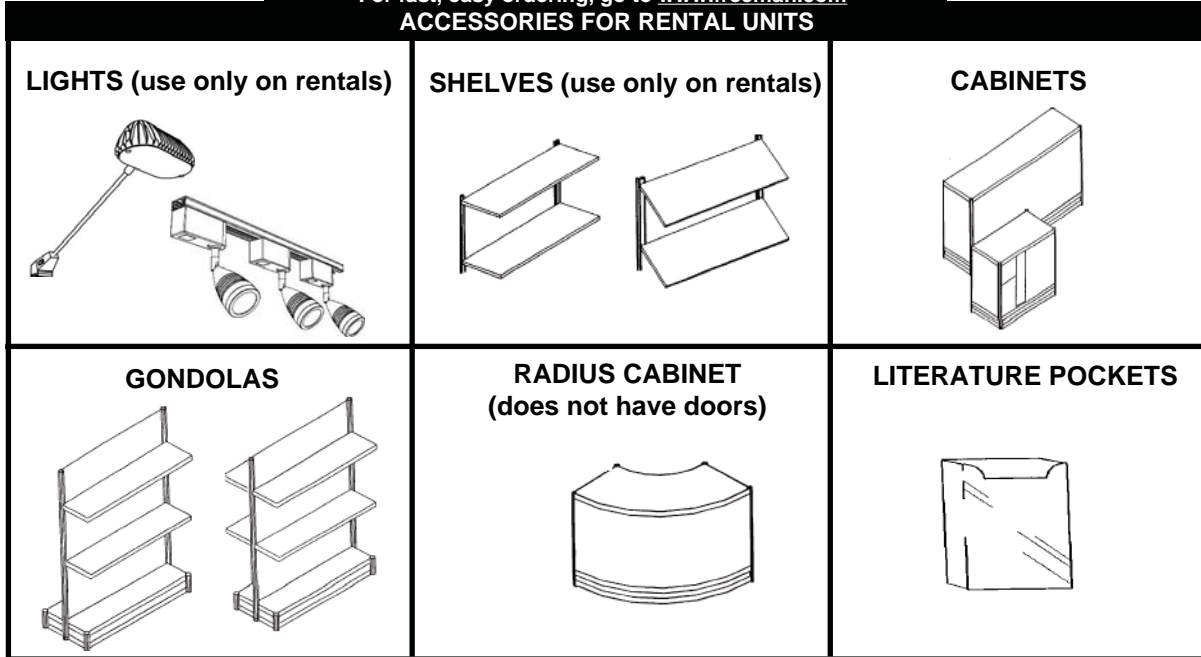

Qty	Part #	Description	Discount Price	Standard Price	Total
<b>LIGHT FIXTURES</b> (electrical service & labor to install lights not included)					
___	172512	Arm Light .....	127.20	178.10	_____
___	172514	4' Tracklight (3 lights)	392.10	548.95	_____
___	17252	Halogen Light .....	127.20	178.10	_____

<b>CABINETS &amp; LOCKS</b>					
Cabinets					
<input type="checkbox"/> Black Fabric <input type="checkbox"/> Blue Fabric <input type="checkbox"/> Gray Fabric <input type="checkbox"/> White PVC					
___	17305	1M x ½M x 36" High.....	434.10	607.75	_____
___	17306	1M x ½M x 42" High.....	434.10	607.75	_____
___	17308	2M x ½M x 36" High.....	697.10	975.95	_____
___	17309	2M x ½M x 42" High.....	697.10	975.95	_____
___	173010	1M Radius x ½M x 36" High.	644.30	902.00	_____
___	173011	1M Radius x ½M x 42" High..	644.30	902.00	_____
(Radius Cabinets do not have doors)					
___	17301	Cabinet Lock .....	N/A	N/A	_____
Inside Shelves Available ..... Quoted on Request					

Qty	Part #	Description	Discount Price	Standard Price	Total
<b>GONDOLAS</b>					
Gondolas					
<input type="checkbox"/> Blue Fabric <input type="checkbox"/> Gray Fabric <input type="checkbox"/> Perboard <input type="checkbox"/> White PVC					
___	174541	Single Sided 1M x 4' High...	393.65	551.10	_____
___	174542	Double Sided 1M x 4' High..	525.65	735.90	_____
___	174581	Single Sided 1M x 8' High...	651.05	911.45	_____
___	174582	Double Sided 1M x 8' High..	868.20	1,215.50	_____

<b>SHELVES</b>					
___	17201	1M Straight (37" x12") .....	78.90	110.45	_____
___	17206	1M Angled (37" x 12") .....	104.10	145.75	_____

<b>LITERATURE POCKETS</b>					
___	174015	For 8½ x 11 Literature .....	38.60	54.05	_____

<b>TOTAL COST</b>					
_____	Sub-Total	+	_____	8.9% Tax	= _____
			_____	Total Cost	_____

Don't see what you need?  
 Please call Exhibitor Sales at (404) 253-6494.

*\* Remember to make a selection for items with checkboxes. Otherwise, a selection will be made for you.*

# FLEXING TO FIT YOUR NEEDS

---

TotalFlex® provides the ability to configure exhibits to fit your space, budget and vision from show to show. Available for rent or for purchase, this pop-up display is versatile, lightweight and durable, and setup can be completed without tools in only a few minutes.



Call customer service at the number listed on the Quick Facts. For fast, easy ordering, go to [www.freeman.com](http://www.freeman.com)

The TotalFlex® solution is the most versatile exhibit option available:

- Floor unit cases easily convert into a podium.
- Velcro-compatible fabric panels available in a wide selection of colors.
- Compatible with shelves, lights and other innovative trade show accessories.
- Available in a variety of sizes for rent or purchase, including a tabletop version (shown on front).
- Freeman offers full graphic and logo design solutions.\*
- All TotalFlex® rental units include installation & dismantling of display system, material handling, 9'x10' or 9'x20' Classic Carpet with nightly vacuuming, 200-watt halogen lights (1 light for the table-top unit, 2 lights per 8x10 unit) as well as power and labor to hang them.

*\*Graphic design elements are priced separately and not included with TotalFlex® order.*



**FLOOR UNITS**

- ▬ 10'w x 8'h Floor Standing Unit
- ▬ 20'w x 8'h Floor Standing Unit

**TABLE TOP UNITS**

- ▬ 6'w x 40"h Table Top Unit
- ▬ 8'w x 40"h Table Top Unit

# FREEMAN

841 Joseph E Lowery Blvd N W  
Atlanta, GA 30318  
(404) 253-6494 Fax: (469) 621-5610  
FreemanAtlantaES@freeman.com

DISCOUNT PRICE  
DEADLINE DATE  
AUGUST 21, 2017

INCLUDE THE FREEMAN METHOD OF  
PAYMENT FORM WITH YOUR ORDER

NAME OF SHOW: **IBTTA 85th ANNUAL MEETING / SEPTEMBER 11 - 12, 2017**

COMPANY NAME: \_\_\_\_\_ BOOTH #: \_\_\_\_\_ BOOTH SIZE: \_\_\_\_\_ X

CONTACT NAME : \_\_\_\_\_ PHONE #: \_\_\_\_\_

E-MAIL ADDRESS : \_\_\_\_\_

For Assistance, please call (404) 253-6494 to speak with one of our experts.

For fast, easy ordering, go to [www.freeman.com](http://www.freeman.com)

## TABLETOP UNIT

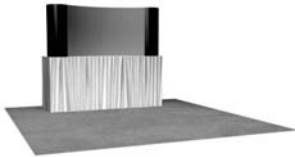

RENTAL			QTY	TOTAL
Size	Discount Price	Standard Price		
40"H x 6'W	1,048.95	1,468.55	_____	_____
40"H x 8'W	1,224.20	1,713.90	_____	_____
PURCHASE*				
Size	Discount Price	Standard Price		
40"H x 6'W	1,303.40	1,824.75	_____	_____
40"H x 8'W	1,478.15	2,069.40	_____	_____

\*Shipping Not Included

**Rental Units Include:**  
Draped Table (select color below)  
Classic Carpet 9' X 10' (select color below)  
Installation & Dismantle of Exhibit  
Material Handling of Exhibit  
Nightly Vacuuming  
1-200 Watt Halogen Light (Power (500 watts) for LIGHTS only and Labor to hang lights)

**Purchase Units Include:**  
1-Case  
One Time Installation & Dismantle

Header Identification Sign - (white with black text) Indicate copy below:

**Fabric Panel Colors for All Units:**  Black  Gray

**Additional Fabric Panel Colors for Purchase Units Only:**  
 Blaze Red  Blueberry  Emerald  Silver

**\*Other Colors Also Available for Purchase Units**

**9' x 10' Classic Carpet:**  Black  Blue  Green  Gray  
 Latte  Midnight Blue  Plum  Red  Red Pepper  Tuxedo

**Table Drape:**

Black  Blue  Brown  Green  Flax  
 Gold  Gray  Plum  Red  White

## FLOOR UNIT

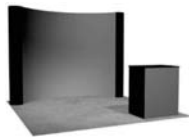

RENTAL			QTY	TOTAL
Size	Discount Price	Standard Price		
8'H x 8'W	1,748.00	2,447.20	_____	_____
8'H x 10'W	2,091.50	2,928.10	_____	_____
PURCHASE*				
Size	Discount Price	Standard Price		
8'H x 8'W	2,937.40	4,112.35	_____	_____
8'H x 10'W	3,450.80	4,831.10	_____	_____

\*Shipping Not Included

**Rental Units Include:**  
Classic Carpet 9' X 10' (select color below)  
Installation & Dismantle of Exhibit  
Material Handling of Exhibit  
Nightly Vacuuming  
1-Podium - 8'H X 10'W unit only  
2-200 Watt Halogen Lights (Power (500 watts) for LIGHTS only and Labor to hang lights)

**Purchase Units Include:**  
2-Cases  
One Time Installation & Dismantle  
1-Podium - 8'H X 10'W unit only

Header Identification Sign - (white with black text) Indicate copy below:

**Fabric Panel Colors for All Units:**  Black  Gray

**Additional Fabric Panel Colors for Purchase Units Only:**  
 Blaze Red  Blueberry  Emerald  Silver

**\*Other Colors Also Available for Purchase Units**

**9' x 10' Classic Carpet:**  Black  Blue  Green  Gray  
 Latte  Midnight Blue  Plum  Red  Red Pepper  Tuxedo

All Classic carpet contain recycled content and are recyclable.

## CUSTOM GRAPHIC / PHOTO PANELS

Our custom graphic panels can dramatically enhance your exhibit's appearance.

Please check the box to have an Exhibitor Sales Specialist contact you to assist in creating a unique exhibit.

OPTIONAL ACCESSORIES			RENTAL			PURCHASE			
Part #	Description	Qty	Discount Price	Standard Price	Total	Qty	Discount Price	Standard Price	Total
1715800	2-200 Watt Halogen Light Kit	_____	218.90	306.45	_____	_____	310.25	434.35	_____
1715801	1-200 Watt Halogen Light Kit	_____	113.95	159.55	_____	_____	224.40	314.15	_____
1715802	Straight Shelf	_____	89.10	124.75	_____	_____	156.60	219.25	_____
1715803	Angled Shelf	_____	89.10	124.75	_____	_____	156.60	219.25	_____

## QUICK TIPS

\* If shipping literature or products, material handling rates will apply.

\* Order in advance to save time, money and ensure availability. **Orders received after the deadline date or without payment will be charged the Standard Price.**

### PURCHASE UNITS TOTAL COST

Sub-Total + 8.9% Tax = Total Cost

### RENTAL UNITS TOTAL COST

Sub-Total + 8.9% Tax = Total Cost

# SEEING IS BELIEVING

Quality graphics contribute significantly to the impact of your exhibit. With state-of-the-art design and printing capabilities, Freeman brings your banners, signage, and exhibit graphics to life in a larger-than-life way. Our graphics products redefine “high definition,” which means your brand has never been seen like this before.

- Photo-quality / high-resolution printing on a variety of rigid and rolled material including honeycomb, foam, Polyfoam, PVC, acrylic, fabric, vinyl and mesh materials
- Grand Format printers provide high-resolution digital printing of single and double-sided banners in virtually any size
- Electronic file transfer, in-house printing, and company-wide procedure standardization allow us to control quality, cost and scheduling on a nationwide basis
- Freeman’s extensive resources ensure that last minute repairs and replacements are handled efficiently as needed, no matter where your event may be located

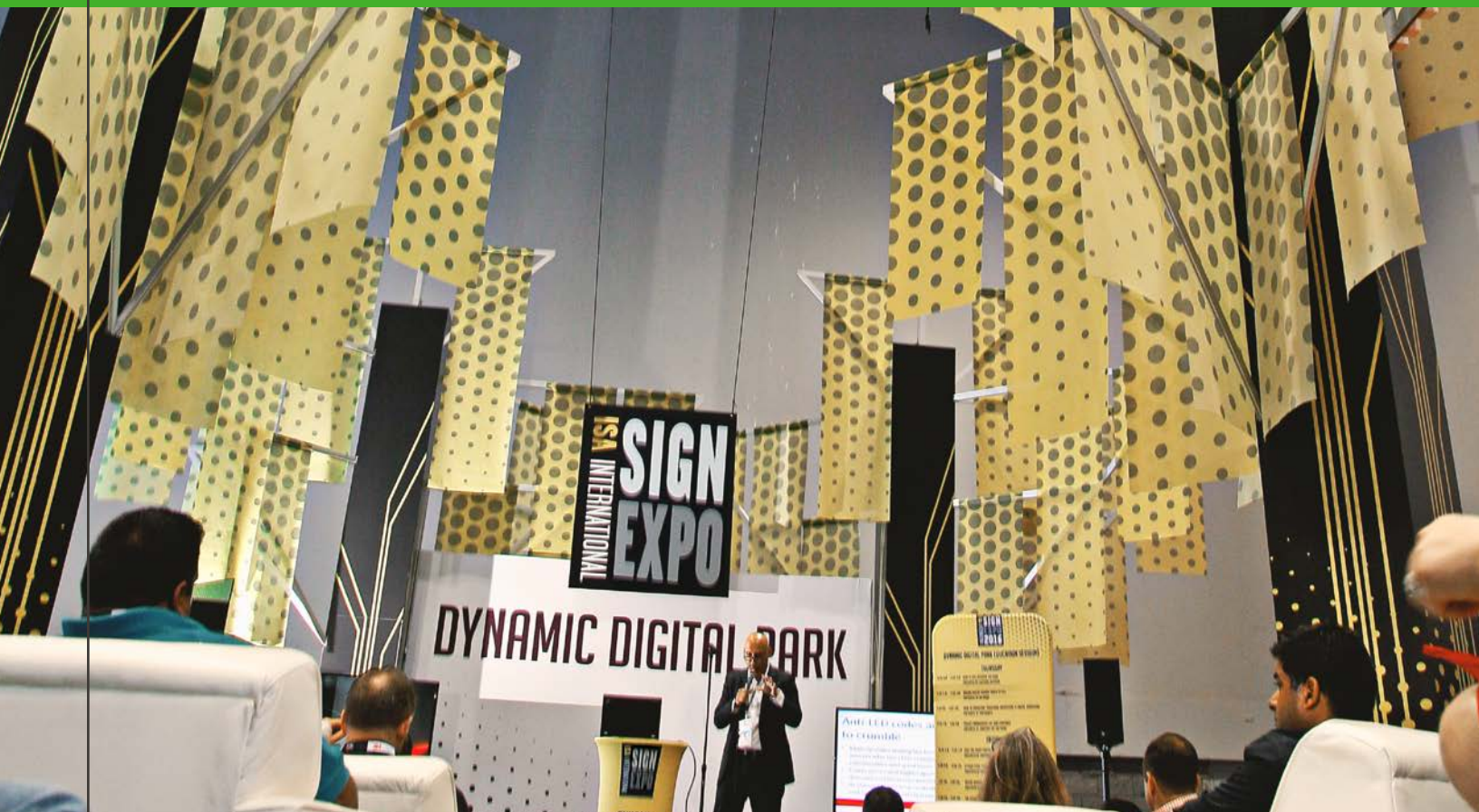

Call customer service at the number listed on the Quick Facts. For fast, easy ordering, go to [www.freeman.com](http://www.freeman.com)

## CREATING VISUAL EXCITEMENT

Quality graphics contribute significantly to the impact of your exhibit. Vivid colors and sharp images attract attention, build traffic, and communicate messages more effectively. Freeman has invested in the latest printing technology and has the skills to provide you with the finest high-resolution digital graphic reproduction available.

## STATE-OF-THE-ART CAPABILITIES

Freeman can provide four-color, photo-quality, high-resolution digital printing in virtually any size for banners, signage, exhibit graphics, and more. Each Freeman location has stand-alone printing capabilities, along with two additional graphic locations for additional support and for special requirements.

## SUPERIOR QUALITY CONTROL

Electronic file transfer, in-house printing, and company-wide standardization of procedures allow us to control quality, cost and scheduling for our customers on a nationwide basis. Last minute repairs and replacements are handled efficiently through our nationwide resources.

## DEPTH OF RESOURCES

- 5M UV roll printers provide grand format, four-color, high-resolution digital printing of single and double-sided banners up to 10' wide and virtually any size with seams.
- 3M Dye Sublimation printers provide 10' fabric graphics that work perfectly in our SmartWall panel system.
- UV flatbeds print directly to a variety of ridged materials and offer a 100% recyclable graphic when using a cardboard substrate.
- Large format Eco-Solvent printers produce high quality graphics for wall, carpet and window applications.
- 3M high speed digital cutters allow for precise cutting of multiple panel applications and also custom router graphic panels.
- Computer-aided graphic design & layout available for your assistance.

## REPRODUCTION AND INSTALLATION

- Suspended banners
- Accent graphic photo panels
- Large format signage and banners
- Logo reproduction
- Backlit displays and murals
- Four-color carpet image printing

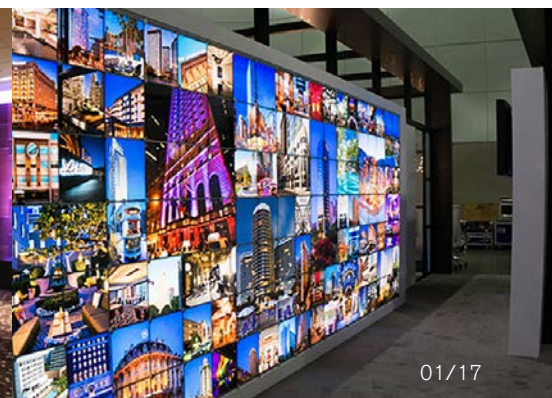
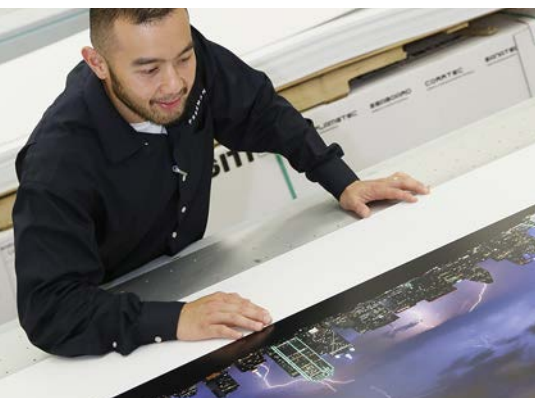



# FREEMAN

841 Joseph E Lowery Blvd N W  
Atlanta, GA 30318  
(404) 253-6494 Fax: (469) 621-5610  
FreemanAtlantaES@freeman.com

DISCOUNT PRICE  
DEADLINE DATE  
AUGUST 21, 2017

INCLUDE THE FREEMAN METHOD OF  
PAYMENT FORM WITH YOUR ORDER

NAME OF SHOW: **IBTTA 85th ANNUAL MEETING / SEPTEMBER 10 - 13, 2017**

COMPANY NAME: \_\_\_\_\_ BOOTH #: \_\_\_\_\_ BOOTH SIZE: X \_\_\_\_\_

CONTACT NAME: \_\_\_\_\_ PHONE #: \_\_\_\_\_

E-MAIL ADDRESS: \_\_\_\_\_

For Assistance, please call (404) 253-6494 to speak with one of our experts.

For fast, easy ordering, go to [www.freeman.com](http://www.freeman.com)

## GRAPHICS

To order your graphics, complete this order form and attach your sign copy or electronic file.

Please see artwork guidelines for electronic files on page 2 of this form.

Note: All graphics are subject to a 100% Cancellation Charge.

### DIGITAL GRAPHICS

Freeman has the capabilities to provide you with the finest digital graphic reproduction available. Capabilities include four-color, photo-quality, high-resolution digital printing virtually any size for banners, signage, exhibit graphics and more.

\_\_\_\_\_ L X \_\_\_\_\_ W = \_\_\_\_\_ sq.ft.

sq. ft. \_\_\_\_\_ \$ 21.35 per sq. ft. discount price  
x or = \$ \_\_\_\_\_  
\$ 32.05 per sq. ft. standard price

- Minimum order per graphic 9 sq. ft. (1296 sq. in.)
- Double sq. ft. for double-sided graphics
- Round sq. ft. to next whole increment
- File conversion, retouching, cloning or color correcting may incur additional labor charges. (See reverse side for graphic guidelines.)

### LARGE DIGITAL GRAPHICS

Please call an Exhibitor Sales Specialist for price quotes on graphics over 80 sq. ft.

File Information:

Electronic File Name \_\_\_\_\_

Application \_\_\_\_\_

PMS Colors \_\_\_\_\_

### Backing Material:

- |   |  |
|---|--|
| <input type="checkbox"/> Freeman Foam (Foamcore)        | <input type="checkbox"/> Masonite                      |
| <input type="checkbox"/> Freeman PVC (PVC)              | <input type="checkbox"/> Plexi                         |
| <input type="checkbox"/> Freeman HD Foam (Gatorfoam)    | <input type="checkbox"/> Freeman Honeycomb (Eco-Board) |
| <input type="checkbox"/> Freeman Polyfoam (Ultra Board) | <input type="checkbox"/> Other                         |

The product offered has recycled content or has eco-friendly attributes and is 100% recyclable according to the manufacturer's specifications.

Vertical \_\_\_\_\_ Horizontal \_\_\_\_\_ Use Your Judgment For Sign Layout \_\_\_\_\_

### Special Instructions

### STANDARD SIZES

#### CHOOSE YOUR SIZE:

QTY.	Discount Price	Standard Price	TOTAL
7" x 11"	@ 60.30	90.45 =	_____
7" x 22"	@ 62.45	93.70 =	_____
7" x 44"	@ 69.00	103.50 =	_____
9" x 44"	@ 91.10	136.65 =	_____
11" x 14"	@ 64.25	96.40 =	_____
14" x 22"	@ 91.10	136.65 =	_____
14" x 44"	@ 103.55	155.35 =	_____
22" x 28"	@ 108.80	163.20 =	_____
28" x 44"	@ 164.90	247.35 =	_____
20" x 60"	@ 221.40	332.10 =	_____

(white only)

Note: File conversion, retouching, cloning or color may incur additional labor charges. (See reverse side for graphic guidelines.)

### INDICATE YOUR SIGN COPY HERE:

\* Please feel free to attach additional sign copy on separate page.

Vertical

Horizontal

Use Your Judgment For Sign Layout

Background Color: \_\_\_\_\_

Lettering Color: \_\_\_\_\_

### TOTAL COST

Sub-Total + 8.9 % Tax = Total Cost

## CUSTOMER GUIDELINES FOR SUBMITTING GRAPHICS ARTWORK

*Our goal is to provide you with the best possible quality graphics for your event or exhibit. You can help us in that effort by providing digital art files using the following guidelines. If you are sending us completed, print-ready files, please pass the following information on to your graphics designer or art department. Two overall considerations for submitting acceptable artwork involves proper resolution or size of the file to avoid poor quality images, and proper color matching information and proofs to ensure accurate color reproduction.*

### PLEASE PROVIDE THE FOLLOWING WHEN SUBMITTING ART

RASTER ART (photos, logos containing any continuous tone images):

- Art submitted at 1:1 (100%), resolution should be no less than 60 dpi (100 dpi preferred)
- Art submitted at 2:1 (50%), resolution should be no less than 120 dpi (200 dpi preferred)
- Art submitted at 4:1 (25%), resolution should be no less than 240 dpi (400 dpi preferred)

VECTOR ART:

- Logos should be vector and have outlined fonts (if provided as bitmap, please use high-res images)

FONTS and LINKS

- Supply all fonts used in your design (zip Mac fonts). If unsure how to collect fonts, convert them to outlines
- Supply all links used in your document. Use packaging feature if available. If unsure how to collect links, embed them in the file when saving.

COLOR

- If PMS color matching is required, please use original Pantone + Solid Coated swatches in your artwork. Modifying Pantone names will result in printing default color (CMYK)
- CMYK artwork will be produced "As Is". Our color output is balanced and vibrant.
- Convert RGB art to CMYK if possible.
- If you are sending Certified Color Proofs (Gracol, Swop, Fogra), please provide ICC file information used to print your samples. Best option would be to include ICC chart on your prints.

ARTWORK IN THE STRUCTURE

- Please note that any panels going in the metal frame will hide 1/4" of your art all the way around. If you have a continuous wall where individual panels are divided by metal, use 1.25" spacing in between each panel to account for gaps and the natural flow of the graphics.

### ACCEPTABLE FILE SOFTWARE

We are capable of working with both PC and MAC based software, and can accept art created with the ADOBE Creative Suite - Illustrator, InDesign, and Photoshop

Always provide the following:

- Native files with fonts and links (zipped)
- High-res PDF-X/4 exports of the files

### ACCEPTABLE FILE TYPES and SUPPORT FILES

NATIVE FILES:

- AI CLOUD (CC) file with Packaged supporting links and fonts. You may keep images linked but Packaging feature must be used.
- AI (CS6, CS5, CS4...) file with embedded links and outlined fonts
- EPS file with embedded links and outlined fonts
- INDD file with Packaged supporting links and fonts

PRINT FILES:

- High-res PDF-X/4 (preferred)
- AI with PDF content (choose this option when saving file)
- EPS files with embedded links and outlined fonts

RASTER OR BITMAP ART:

- Photoshop EPS (preferred, use 8-bit preview, Max, Quality JPG compression)
- PSD (make sure font layers are rasterized)
- TIFF, JPG (quality 8 and higher)

Mac users: Use Zip or Stuffit programs when submitting fonts other than OTF (Open Type Fonts)

### WAYS TO SEND ARTWORK

• Files below 10 MB can be delivered via email. Larger files may be posted to Freeman's FTP site. You may get the password and other needed information from your Freeman service representative in order to post files. However, a hard copy proof and backup of the files on CD-Rom/DVD may be required to be sent via overnight delivery in addition to posting the electronic files. Please call (404) 253-6494 for assistance.

# UNION JURISDICTIONS ATLANTA, GA

To assist you in planning for your participation in this upcoming exposition, we are certain you will appreciate knowing in advance that union labor may be required for certain aspects of your exhibit handling. To help you understand the jurisdiction of the various unions, we ask that you read the following:

## EXHIBIT INSTALLATION AND DISMANTLING:

Currently we have an agreement with the Local Stagehand Union to provide labor for display installation and dismantling. Full time employees of the exhibiting companies, however, may set their own exhibits without the assistance of this Local. Any labor services that may be required beyond what your regular full time employees can provide must be rendered by the Union or an Exhibitor Appointed Contractor. Labor can be ordered in advance by returning the Display Labor Form, or at show site, at the Freeman Service Center.

## MATERIAL HANDLING:

Exhibitors and full time employees of exhibiting companies may hand carry their own materials into the exhibit facility. However, the use or rental of dollies, flat trucks, pallet jacks or other mechanical equipment is not permitted. Freeman has the responsibility of receiving and handling all exhibit materials and crates, with the exception of items Exhibitors hand carry. Freeman will control access to the loading docks in order to provide for a safe and orderly move in/out. Unloading or reloading at the dock of any and all contracted carriers will be handled by Freeman.

Vehicles must not be left unattended at the loading areas. Any unattended vehicles will be towed at the owner's expense.

Fire Marshal regulations absolutely prohibit the storage of empty containers in the exhibit hall. Arrangements have been made with Freeman to store empty crates and containers. Please refer to the Material Handling section of this manual for information regarding the handling of empties, disposal of skids, etc.

## GRATUITIES:

Tipping is expressly prohibited. This includes such practices as giving money, merchandise or other special consideration for services rendered. Please do not give breaks other than mid-morning and mid-afternoon, when the union has a scheduled 15 minute paid break. Meal breaks are one hour. Any attempt to solicit a gratuity by an employee should be reported immediately to the Exhibit Manager or a Freeman Supervisor.

## SAFETY:

Standing on chairs, tables or other rental furniture is prohibited. This furniture is not engineered to support your standing weight. Freeman cannot be responsible for injuries or falls caused by the improper use of this furniture. If assistance is required in assembling your booth, please order the appropriate labor on the Display Labor Form and the necessary ladders and tools will be provided.

# LET US DO THE HEAVY LIFTING

Freeman specialists are ready to assist you with all of your exhibit requests, from beginning to end. And when it comes to installing and dismantling exhibits, we make no exceptions. Whether it's shipping and storage, emergency on-site repairs, basic installation and dismantling or support service coordination, including electrical, furnishings and more, Freeman has the resources and capabilities to ensure the most successful show experience possible.



Call customer service at the number listed on the Quick Facts. For fast, easy ordering, go to [www.freeman.com](http://www.freeman.com)

Freeman installation & dismantling experts work closely with you to coordinate every phase of your trade show participation, including:

- Pre-planning and budget consultation
- Skilled labor coupled with support services coordination - electrical, furnishings, floral, transportation, and audio visual
- On-site supervisors with dedicated floor managers
- Full, in-house carpentry for emergency repairs and refurbishing
- Post-show evaluations focused on incremental improvement to meet rapidly changing market conditions based upon customer feedback
- Post-show evaluations that help identify small changes that make big impacts

## ON-SITE SUPERVISION

You may wish to supervise labor on your own, but if you need assistance, Freeman installation & dismantling experts will get the job done as an extension of your team.

### If You Use Freeman Staff

Exhibits can be set up prior to your arrival under the direction of Freeman I&D supervisors.

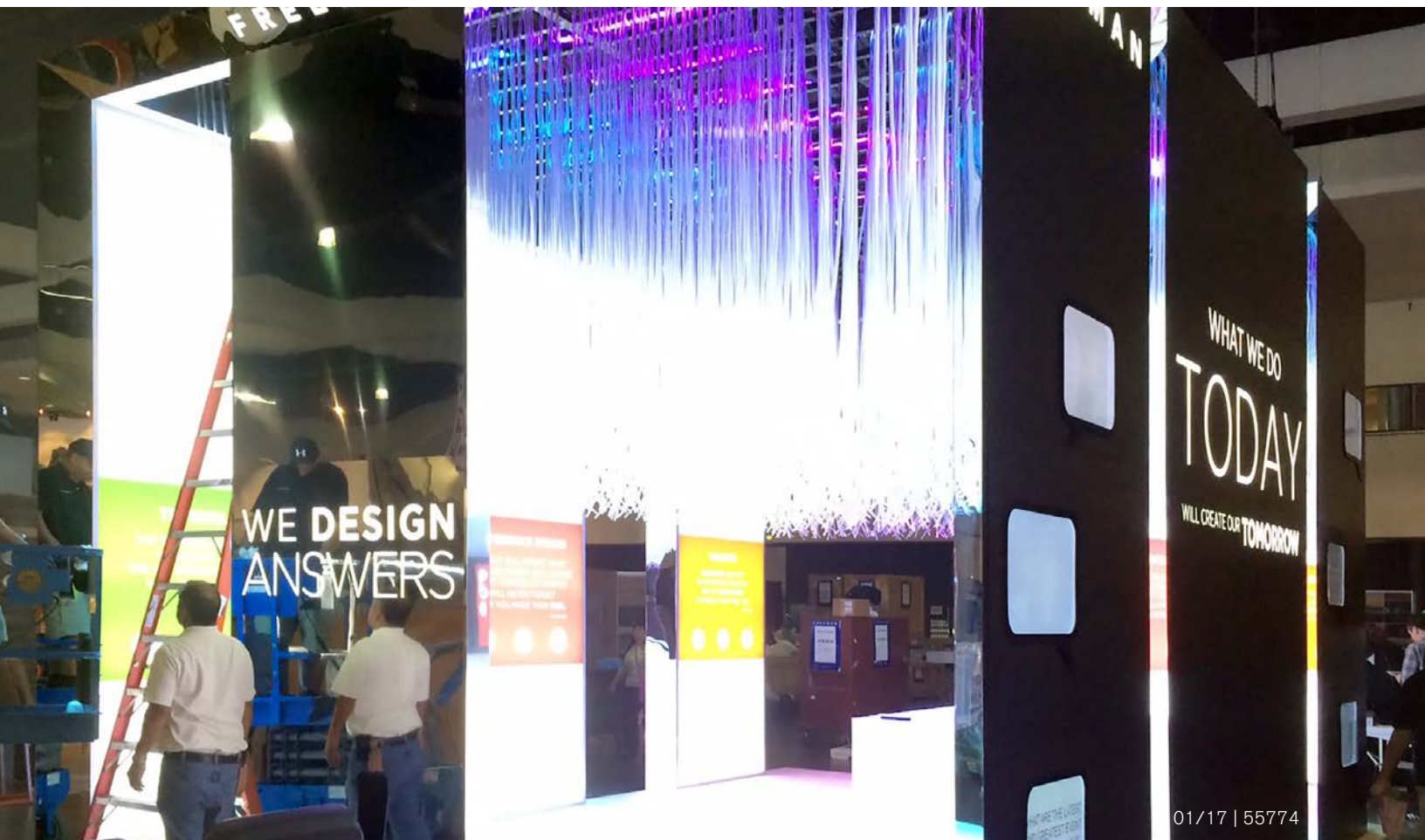

01/17 | 55774

# FREEMAN

841 Joseph E. Lowery Blvd N W  
 Atlanta, GA 30318  
 (404) 253-6494 Fax: (469) 621-5610  
 FreemanAtlantaES@freeman.com

**INCLUDE THE FREEMAN METHOD OF PAYMENT FORM WITH YOUR ORDER**

NAME OF SHOW: IBTTA 85th ANNUAL MEETING / SEPTEMBER 10 - 13, 2017

COMPANY NAME \_\_\_\_\_ BOOTH #: \_\_\_\_\_

CONTACT NAME: \_\_\_\_\_ PHONE #: \_\_\_\_\_

E-MAIL ADDRESS \_\_\_\_\_

For Assistance, please call 404-253-6494 to speak with one of our experts.

For fast, easy ordering, go to [www.freeman.com/store](http://www.freeman.com/store)

## DISPLAY LABOR (One Hour Minimum per Worker)

Description	Advance Price	Show Site Price
<b>Straight Time-</b> 8:00 A.M. to 5:00 P.M. Monday through Friday .....	\$ 93.00	\$130.25
<b>Overtime-</b> 5:00 P.M. to 12:00 A.M. Monday through Friday All day Saturday & Sunday .....	\$ 139.50	\$195.50
<b>Double Time-</b> Midnight to 8:00 A.M. and recognized holidays.....	\$ 186.00	\$260.50

- **Show Site prices will apply to all labor orders placed at show site.**
- Price is per person/per hour.
- Start time guaranteed only at start of working day.
- One hour minimum per person - labor thereafter is charged in half (1/2) hour increments.
- Labor must be canceled in writing, 24 hours in advance to avoid a one (1) hour cancellation fee per worker.
- When scheduling dismantle labor, be sure to allow sufficient time for empty containers to be returned to your booth.
- Freeman supervised jobs will be completed at our discretion prior to show opening and before the hall must be cleared. **Please include setup plan/photo, special instructions & inbound shipping information with this order.**

## INSTALLATION LABOR

**Freeman Supervised Labor - Please complete the reverse side of this form.**

- Installation of your exhibit will be completed at our discretion prior to show opening.
- The charge for this service is 30% of the total installation labor bill, with a minimum of \$45.00.

Emergency contact: \_\_\_\_\_ Phone Number: \_\_\_\_\_

**Exhibitor Supervised Labor (Supervisor must check in at Service Desk to pick up labor)**

Supervisor will be: \_\_\_\_\_ Phone Number: \_\_\_\_\_

Date	Start Time	No. of People	Approx. Hrs. per Person	Total Hrs.	Hourly Rate	Estimated Total Cost
_____	_____	_____	x _____ = _____	_____	@ \$ _____ = \$ _____	_____
_____	_____	_____	x _____ = _____	_____	@ \$ _____ = \$ _____	_____
_____	_____	_____	x _____ = _____	_____	@ \$ _____ = \$ _____	_____
Freeman Supervision (30%/\$45.00)						= \$ _____
Tax						= \$ <b>(N/A)</b>
Total Installation						= \$ _____

## DISMANTLE LABOR

**Freeman Supervised Labor - Please complete the reverse side of this form.**

- Freeman is not responsible for product or literature that is not properly packed and labeled by exhibitor.
- The charge for this service is 30% of the total dismantle labor bill, with a minimum of \$45.00.

Emergency contact: \_\_\_\_\_ Phone Number: \_\_\_\_\_

**Exhibitor Supervised Labor(Supervisor must check in at Service Desk to pick up labor)**

Supervisor will be: \_\_\_\_\_ Phone Number: \_\_\_\_\_

Date	Start Time	No. of People	Approx. Hrs. per Person	Total Hrs.	Hourly Rate	Estimated Total Cost
_____	_____	_____	x _____ = _____	_____	@ \$ _____ = \$ _____	_____
_____	_____	_____	x _____ = _____	_____	@ \$ _____ = \$ _____	_____
_____	_____	_____	x _____ = _____	_____	@ \$ _____ = \$ _____	_____
Freeman Supervision (30%/\$45.00)						= \$ _____
Tax						= \$ <b>(N/A)</b>
Total Dismantle						= \$ _____

**FREEMAN installation & dismantle labor**

NAME OF SHOW: **IBTTA 85th ANNUAL MEETING / SEPTEMBER 10 - 13, 2017**

COMPANY NAME: \_\_\_\_\_ BOOTH#: \_\_\_\_\_

CONTACT NAME: \_\_\_\_\_ PHONE#: \_\_\_\_\_

**FREEMAN SUPERVISED LABOR**

***IN ORDER TO BETTER SERVE YOU - PLEASE COMPLETE THE FOLLOWING INFORMATION IF YOUR DISPLAY IS TO BE SET-UP AND/OR DISMANTLED BY FREEMAN I&D AND YOU WILL NOT BE PRESENT TO SUPERVISE THE INSTALLATION AND/OR DISMANTLE.***

**INBOUND SHIPPING & SET UP INFORMATION**

Freight will be shipped to Warehouse \_\_\_\_\_ Show Site \_\_\_\_\_ Date Shipped \_\_\_\_\_

Total No. of: \_\_\_\_\_ Crates \_\_\_\_\_ Cartons \_\_\_\_\_ Fiber Cases \_\_\_\_\_

Setup Plan/Photo: Attached \_\_\_\_\_ To Be Sent With Exhibit \_\_\_\_\_ In Crate No. \_\_\_\_\_

Carpet: With Exhibit \_\_\_\_\_ Rented From Freeman \_\_\_\_\_ Color \_\_\_\_\_ Size \_\_\_\_\_

Electrical Placement: \_\_\_\_\_ Drawing Attached \_\_\_\_\_ Drawing With Exhibit \_\_\_\_\_

Electrical Under Carpet \_\_\_\_\_

Comments: \_\_\_\_\_

Graphics: With Exhibit \_\_\_\_\_ Shipped Separately \_\_\_\_\_

Comments: \_\_\_\_\_

Special Tools/Hardware Required: \_\_\_\_\_

**OUTBOUND SHIPPING INFORMATION**

SHIP TO: \_\_\_\_\_

\_\_\_\_\_

\_\_\_\_\_

\_\_\_\_\_

**METHOD OF SHIPMENT**

- Freeman Exhibit Transportation:**
- Standard Ground
  - Air Freight       Next Day       2nd Day       Deferred       Expedited
- Other (list carrier name & phone number):**
- Other Common Carrier: \_\_\_\_\_
  - Other Air Freight: \_\_\_\_\_
  - Van Line: \_\_\_\_\_

**FREIGHT CHARGES**

- Prepaid       Collect
- Bill To: \_\_\_\_\_
- \_\_\_\_\_
- \_\_\_\_\_

**In the event your selected carrier fails to show on final move-out day, please select one of the following options:**

- Reroute via Freeman's choice
- Deliver back to Freeman warehouse at Exhibitor's expense.

**PLEASE NOTE: Freeman is not responsible for product or literature that is not properly packed and labeled by exhibitor.**

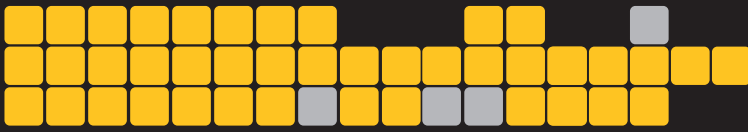

MARRIOTT MARQUIS  
ATLANTA



# AUDIOVISUAL EXHIBITOR SERVICES

NAME OF CONFERENCE:	START DATE:	END DATE:	NO. EVENT DAYS:
COMPANY NAME:	ON-SITE CONTACT NAME:	ON-SITE CONTACT PHONE:	
STREET ADDRESS:	CITY & STATE :	ZIP CODE:	
ROOM/EXHIBIT BOOTH NO.:	DELIVERY DATE:	DELIVERY TIME: <input type="checkbox"/> A.M. <input type="checkbox"/> P.M.	
EMAIL ADDRESS:	PICKUP DATE:	PICKUP TIME: <input type="checkbox"/> A.M. <input type="checkbox"/> P.M.	
ORDERED BY:	ORDERED BY PHONE:		

**PSAV WILL CONTACT YOU DIRECTLY FOR PAYMENT INFORMATION. PRICING IS PER DAY.**

**➤ If you have a special request or need additional equipment, please call 404.586.6255. Email completed form to psav-atlmq@psav.com**

**PRICES ARE FOR EXHIBIT FLOOR ONLY. ALL RENTAL PRICES SUBJECT TO 15% MARKUP IF ORDERED WITHIN 72 HOURS OF SHOW.**

AUDIO EQUIPMENT	QTY	PRICE	VIDEO/DATA DISPLAY	QTY	PRICE
Laptop Sound Port (for external audio)		\$ 60	Laptop (Windows 10/Office 2013)		\$ 215
Wireless Handheld Microphone		\$ 180	Slide Advancer/Laser Pointer		\$ 55
Wireless Lavalier Microphone		\$ 180	<b>MONITORS</b>		
Wireless Headset Microphone: <i>Headset only. Mic will require wireless microphone unit to operate.</i>		\$ 75	22"- 24" Desktop Monitor		\$ 205
Computer Speakers		\$ 40	40" Monitor (includes Cables and choice of Table or Rolling Floor Stand)		\$ 470
Sound System: (2) speakers/(2) stands/ (1) Mixer/Wired Microphone (up to 20 people)		\$ 405	55" Monitor (includes Cables and choice of Table or Rolling Floor Stand)		\$ 750
3-6 Channel Mixer		\$ 65	70" Monitor (includes Cables and choice of Table or Rolling Floor Stand)		Please contact PSAV for quote
CUSTOM ITEMS	QTY	PRICE	ACCESSORIES	QTY	PRICE
Wired Keyboard and Mouse		\$ 45	LED UpLight (color adjustable)		\$ 75
Touch Screen Monitors	Please contact PSAV for quote		Safelock Adjustable Stand		\$ 30
		\$	General AV Cable Lot (small)		\$ 65
		\$			\$
		\$			\$
		\$			\$

## ORDERING INSTRUCTIONS

**To guarantee equipment availability and advanced rate, this order should reach us 21 days prior to delivery.**

Operator labor, if requested, is subject to the prevailing hourly rate with a five-hour minimum. An electronic receipt will be emailed to you.

The total charge per item is determined by multiplying the price by the quantity ordered and by the number of days used. Set/strike labor, 24% service charge and 8.9% tax will be included on the estimate sent to you by the PSAV representative.

**TAX-EXEMPT STATUS** – If you are exempt from payment of state sales tax, a current **State of Georgia Exemption Certificate** must be presented to PSAV.

### CANCELLATIONS:

- A) Cancellations received within 48 hours of the scheduled delivery date are subject to a 50% fee applicable to equipment and tax.
- B) Cancellations received on the day of scheduled delivery or "no-shows" are subject to the full amount of the order to include installation, drayage and tax.

**Pricing does not include labor and service charge. Loss Damage Waivers may apply.**

## SHIPPING INSTRUCTIONS

Any materials being sent to the hotel must be marked as follows:

1. The Atlanta Marriott Marquis
2. Hold for Arrival - Attn: Guest's Name and/or Organization Name
3. Complete Return Address
4. Number of Boxes (ex: Box 1 of 2, Box 2 of 2)
5. Address Packages to: 265 Peachtree Center Ave., Atlanta, GA 30303



### NOTES

- If choosing a monitor, please let us know in the special request section below what monitor cable/connection type and the type of stand you require (floor stand or table top stand).
- PSAV will send you a formal quote after receiving your completed form, then confirm your order once payment is received.
- Security for rental equipment is the responsibility of the client.

**SPECIAL REQUESTS** Please add any items not listed above that you require.







# APPLICATION FOR SERVICES for Exhibit Booths

Name of Event Attending: \_\_\_\_\_ Booth Number: \_\_\_\_\_  
 Company Name: \_\_\_\_\_ On-Site Contact \_\_\_\_\_  
 Address: \_\_\_\_\_ City/State/Zip: \_\_\_\_\_  
 Phone: \_\_\_\_\_ fax: \_\_\_\_\_ email: \_\_\_\_\_

TELEPHONE	# of Lines	# of Phones	Install Date/Time	Uninstall Date/Time	Comments
Direct Inward Dial (DID) \$150 flat fee per installation, phone call charges are additional					
Voicemail \$75.00					
Polycom Speaker Phone \$75 flat fee per phone					
There will be a <b>\$100.00 charge for each phone not returned</b> to the Hotel Technology Department.					

WIRELESS INTERNET	# of devices	Install Date/time	Uninstall Date/time	Comments
High Speed Internet \$75 per device 3mbs – Best for checking emails, updating social network, browse the web				
Enhanced High Speed Internet \$100 per device 6mbs – best for video chat/conference, download large files (movies & music), stream videos				
Connection for credit card machine or to network a printer \$150 removes splash page so machines can access internet without password, MAC Address required				
Wired Internet Available. Please indicate if needed and our IT department will contact you.				

POWER	Quantity	Install Date/time	Uninstall Date/time	Comments
120V Dedicated / 2000 Watts / 20 Amps \$70 each (Included: quad box with (4) outlets.)				
Power Strip and/or Extension Cord \$25 each (specify which or both)				
100 Amps 1 Phase \$350				
100 Amps 3 Phase \$375				
200 Amps 1 Phase \$680				
200 Amps 3 Phase \$725				
Special Order, specify:				

**All service orders must be received 14 business days prior to the install date.**

Taxes (8.9%) and service charges are additional (25%).

**BILLING:**

Credit Card: Name as it appears on card \_\_\_\_\_ Number: \_\_\_\_\_  
 Expiration Date: \_\_\_\_\_

Cardholder Signature: \_\_\_\_\_

OR Guest Room Confirmation number \_\_\_\_\_

Show Name: \_\_\_\_\_

Show Location: \_\_\_\_\_

Show Dates: \_\_\_\_\_



(770) 507-6777  
FAX (770) 474-4676  
plant@tlc-florist.com  
www.tlc-florist.com

N•A•T•I•O•N•A•L  
convention • plant • services

Exhibitor Name: \_\_\_\_\_ Booth Representative: \_\_\_\_\_  
 Firm, Billing Name: \_\_\_\_\_ Purchase Order or Reference Number: \_\_\_\_\_  
 Booth Number: \_\_\_\_\_ Credit Card #: \_\_\_\_\_  
 Billing Address: \_\_\_\_\_ Expiration Date: \_\_\_\_\_ (CVV #) \_\_\_\_\_  
 City: \_\_\_\_\_ State: \_\_\_\_\_ Zip: \_\_\_\_\_ Name of Credit Card Holder as shown on card \_\_\_\_\_  
 Show Decorator: \_\_\_\_\_  
 Phone: \_\_\_\_\_ Fax: \_\_\_\_\_ Authorized Signature: \_\_\_\_\_  
 Cell: \_\_\_\_\_ Email Address: \_\_\_\_\_

Please return completed form with payment to: P.O. Box 538, Rex, GA 30273 (770) 507-6777 (770) 474-4676 FAX  
Please return overnight shipment with payments to: 121 Pine Dr., Stockbridge, GA 30281

**\* PRICES IN BOLD PRINT ARE DISCOUNT PRICES FOR ORDERS RECEIVED 2 WEEKS PRIOR TO EXHIBITOR MOVE-IN**

**FROM SIMPLE AND ELEGANT TO WILD AND COLORFUL!  
LET A TLC DESIGNER CREATE THE PERFECT LOOK JUST FOR YOU!**

If you would like to specify color, size, type flowers, please do so below—**prices start at \$60.00.**

Qty \_\_\_\_\_ tropical flowers—Price \$ \_\_\_\_\_ each

Qty \_\_\_\_\_ Spring flowers—Price \$ \_\_\_\_\_ each

Color \_\_\_\_\_

Width \_\_\_\_\_ Height \_\_\_\_\_

Additional Request: \_\_\_\_\_



*Don't know what you want? Just want a splash of color?  
Let TLC designers choose your fresh seasonal flowers!*

Qty \_\_\_\_\_ TLC pick my colors, size, type flowers \$50.00 ea

Visit [www.tlc-florist.com](http://www.tlc-florist.com) for additional sample pictures.  
For free design assistance, please call 770-507-6777 or email [plant@tlc-florist.com](mailto:plant@tlc-florist.com) with any questions.

TLC Designers can provide the following:

- **Water Features**
  - **Fountains**
  - **Ponds**
  - **Water falls**
  - **Swamps**
  - **Garden Areas**
    - Tropical :**  
(beach scenes;  
rain forests)
    - Seasonal:**  
(Spring, Fall, Holiday)
    - Formal :**  
(serenity garden,  
English garden)
  - **Border Areas:**
    - Hedges**  
(control flow)
    - Lawn or Golf**  
(promotional)
    - Trees**  
(privacy)
- Special services are Available for hospitality Suites, award banquets, And VIP room deliveries.**

**COLORFUL POTS OF VIBRANT FLOWERS!**



Mums—12"-18"H  
**\$20.00/\$30.00**  
each

Qty \_\_\_\_\_

White \_\_\_\_\_

Yellow \_\_\_\_\_

Lavender \_\_\_\_\_

Azaleas—12"H  
**\$35.00/\$45.00** each

Qty \_\_\_\_\_

White \_\_\_\_\_

Pink \_\_\_\_\_

Red \_\_\_\_\_

Bromeliads—12"-18"H  
**\$35.00/\$45.00** each

Qty \_\_\_\_\_

Purple \_\_\_\_\_ Red \_\_\_\_\_

Yellow \_\_\_\_\_ Orange \_\_\_\_\_

*See next  
page for  
green plants.*

**FLORAL ORDER FORM**



770) 507-6777  
 plant@tlic-florist.com  
 www.tlic-florist.com

**Ferns**



Ferns  
 \$35.00/\$45.00 each

Qty \_\_\_\_

**Ivy**



Ivy—10”H x 10”W  
 \$35.00/\$45.00 each

Qty \_\_\_\_

**Pothos**



Pothos—12”H x 12”W  
 \$35.00/\$45.00 each

Qty \_\_\_\_

**3' Green Plants**



\$39.95/\$48.00 each Qty \_\_\_\_

**Standard 4' to 6' Green Plants**



4' @ \$49.95/\$64 each Qty \_\_\_\_  
 5' @ \$59.95/\$80 each Qty \_\_\_\_  
 6' @ \$69.95/\$96 each Qty \_\_\_\_

**7' H & Taller plants & Planters are available**  
 Call 770-507-6777 for price/availability



Planters are 2 1/2' long.

**Top-dressed with azalea (pictured)**  
 Also available with mum  
 Choose flower color for flower choice.

For Top-dressing with fern & azalea  
 \_\_ white, \_\_ pink, \_\_ red

For Top-dressing with fern & mum  
 \_\_ white, \_\_ yellow, \_\_ lavender



4' @ \$125/\$155 each, Qty \_\_\_\_  
 5' @ \$135/\$170 each, Qty \_\_\_\_  
 6' @ \$145/\$185 each, Qty \_\_\_\_

**Seasonal Flowering Plants**  
 Call for Price & Availability

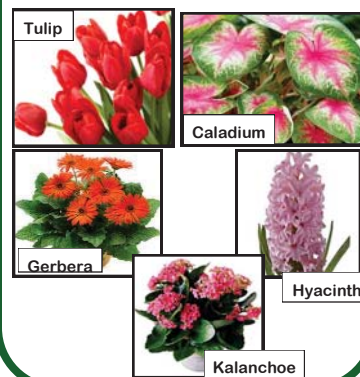

Rental price includes: Decorative container, top dressing, professional maintenance, installation and pick up. There is a one-time \$10.00 charge for **daily** floral delivery. **ALL ORDERS MUST BE PAID - IN - FULL PRIOR TO SHOW CLOSING.** We accept cash, company check, VISA, MASTERCARD, AMERICAN EXPRESS. Adjustments cannot be made after the close of the show. All rental items remain property of TLC Atlanta Convention Plant Services, Inc. **There is a restocking fee for orders cancelled less than 2 weeks prior to show opening. Orders placed after the open of an event may be subject to a delivery fee.**  
**Prices subject to change 2 weeks prior to move in.**

**Order Cost Summary**

Select Container (Included in rental cost)  
 \_\_ Black \_\_ White \_\_ Wicker

Subtotal \_\_\_\_\_

% Sales Tax \_\_\_\_\_

Total \_\_\_\_\_

Chrome, Brass, Terra Cotta, & Other Containers are available.  
 Please call 770-507-6777 for pricing.

**FLORAL ORDER FORM**